

E23A 2" Sanitary Pump Specifications and Performance

SPECIFICATIONS

E23A

FLOW RATE (Adjustable) 0-180 gpm (680 lpm)
PORT SIZE
 Inlet and Outlet 2.0" Tri-Clamp®
AIR INLET 0.50" NPT
AIR EXHAUST 0.75" NPT
SUCTION LIFT
 Teflon® 10' Dry/20' Wet (3.05m/6.10m)
MAX. PARTICLE SIZE (Dia.) 0.625" (15.88mm)
SURFACE FINISH 32 micro-inch (0.8 micrometer)
SHIPPING WEIGHT 125 lbs (56.8kg)

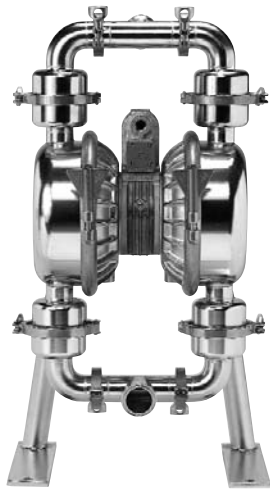

PERFORMANCE

Determined by actual flow meter tests.

E23A

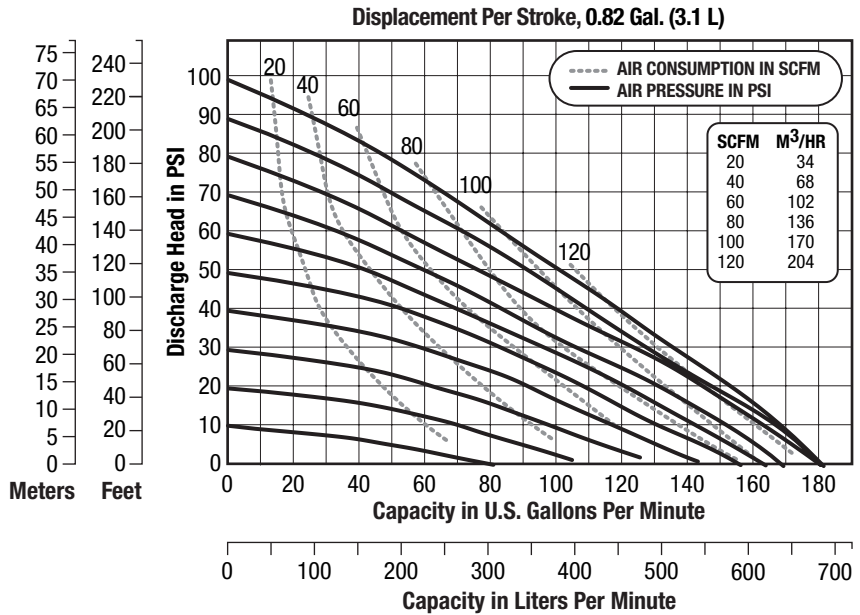

NOTE: For E2 pumps fitted with Teflon® diaphragms, reduce water discharge figures by 20%. Suction lift is reduced to 10' (3.05m) dry and 20' (6.10m) wet.

CAUTION: Do not exceed 125 psig (8.5 bars) air supply or liquid pressure.

DIMENSIONS

Consult factory for certified drawings.

E23A

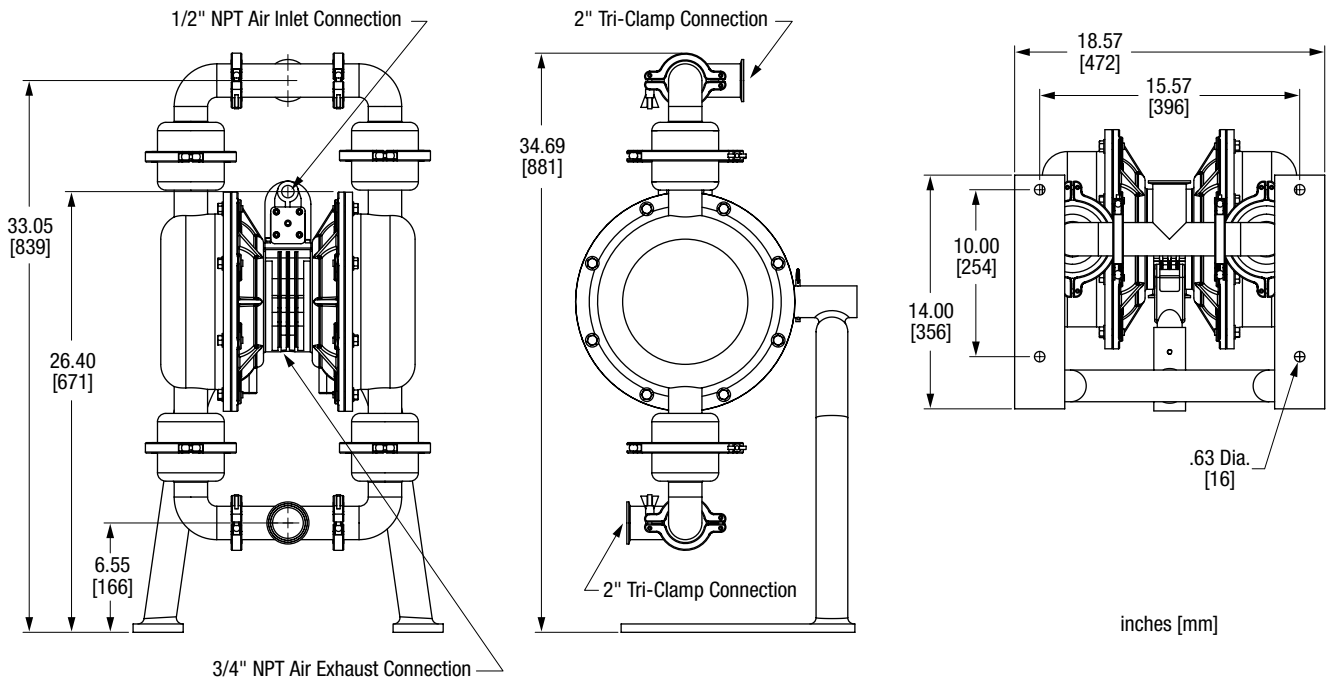

E43A 1-1/2" Sanitary Pump Specifications and Performance

SPECIFICATIONS

E43A

- FLOW RATE** (Adjustable) 0-60 gpm (227 lpm)
PORT SIZE
 Inlet and Outlet 1.5" Tri-Clamp®
AIR INLET 0.50" NPT
AIR EXHAUST 0.75" NPT
SUCTION LIFT
 Teflon® 10' Dry/20' Wet (3.05m/6.10m)
MAX. PARTICLE SIZE (Dia.) 0.375" (9.53mm)
SURFACE FINISH 32 micro-inch (0.8 micrometer)
SHIPPING WEIGHT 75 lbs (34.09kg)



PERFORMANCE

Determined by actual flow meter tests.

E43A

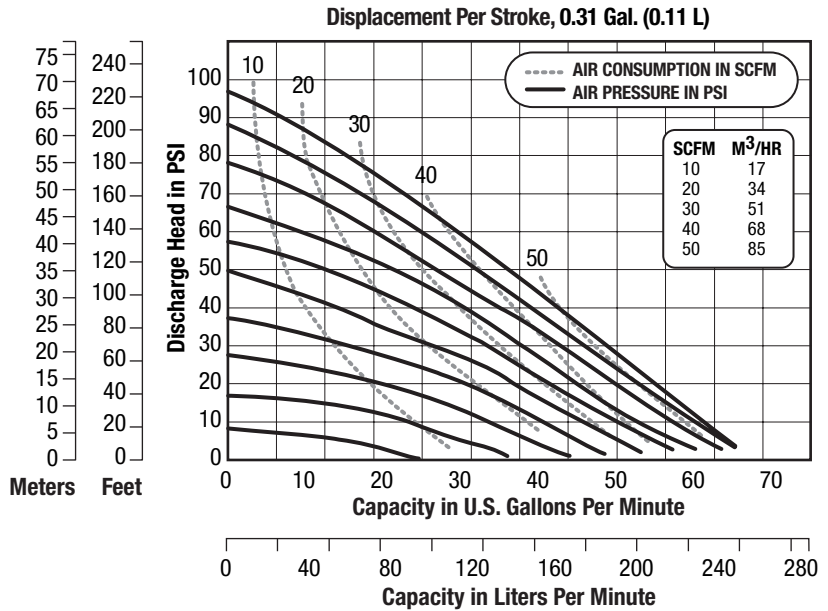

NOTE: For E4 pumps fitted with Teflon® diaphragms, reduce water discharge figures by 20%. Suction lift is reduced to 10' (3.05m) dry and 20' (6.10m) wet.

CAUTION: Do not exceed 125 psig (8.5 bars) air supply or liquid pressure.

DIMENSIONS

Consult factory for certified drawings.

E43A

