

1/2" Elima-Matic Bolted Metal – ATEX

with Metallic Center Sections

E5

E5 Metal Pumps

- Aluminum
- Stainless Steel
- Alloy C

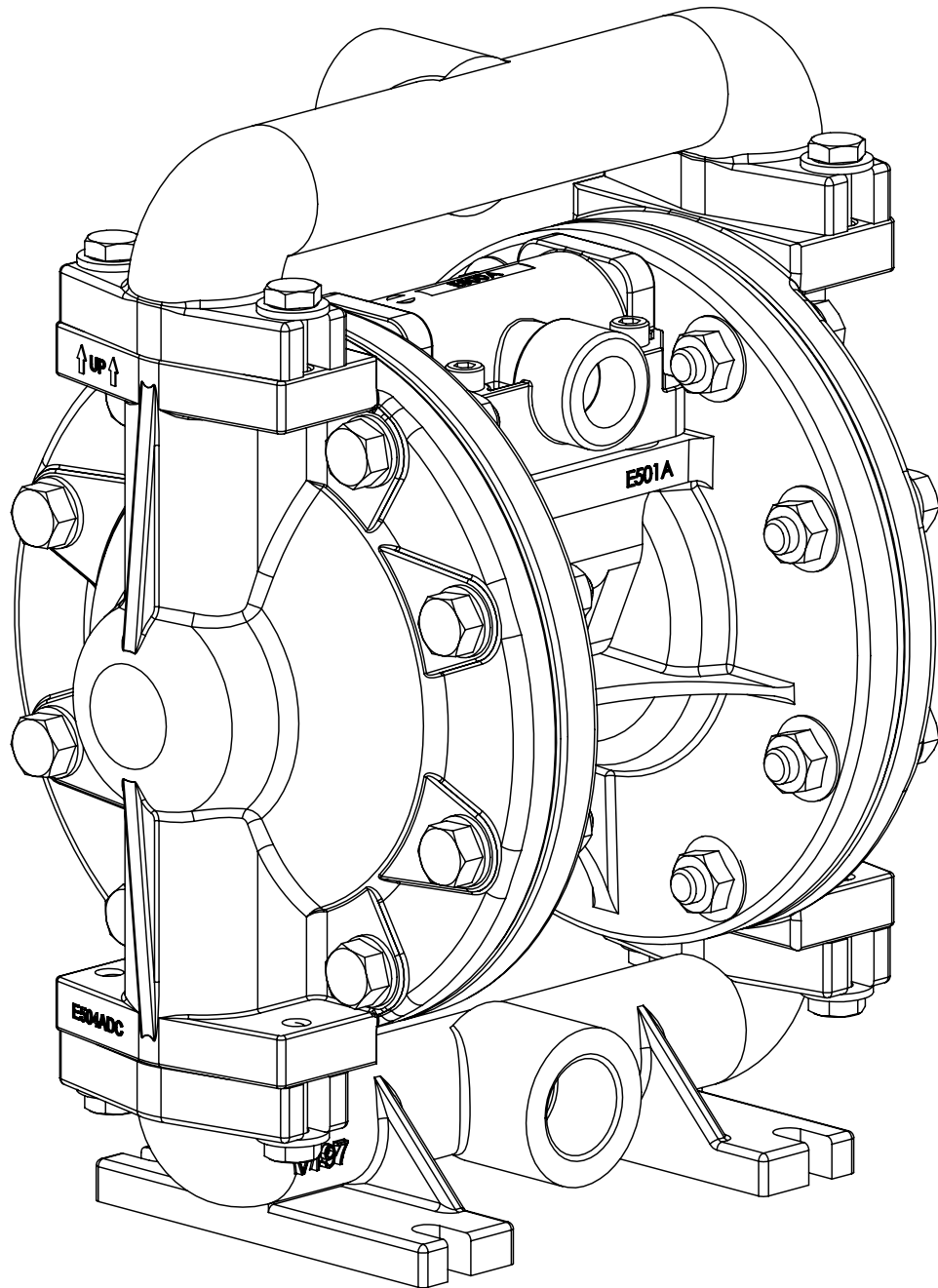

Explanation of Pump Nomenclature

Your Serial #: (fill in from pump nameplate) _____

Your Model #: (fill in from pump nameplate)

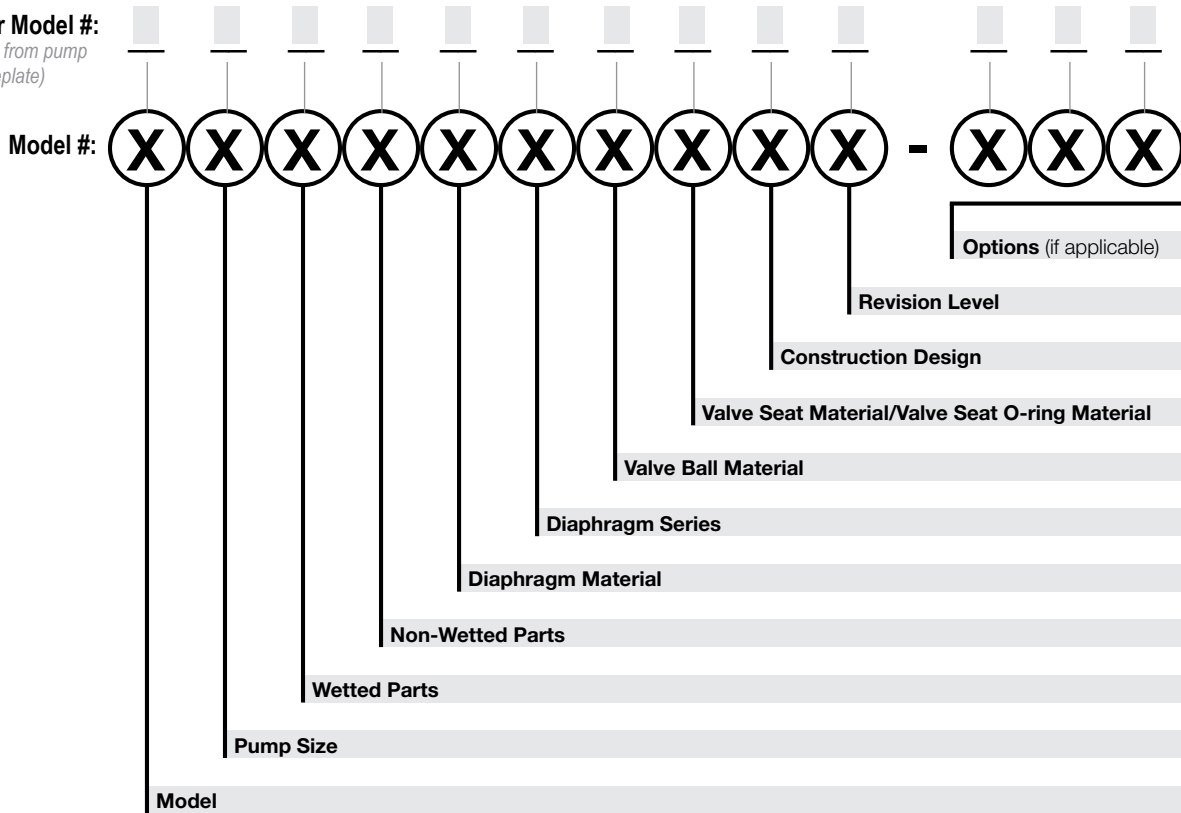

Model

E Elima-Matic
U Ultra-Matic
V V-Series
RE AirVantage

Pump Size

6 1/4"
8 3/8"
5 1/2"
7 3/4"
1 1"
4 1-1/4" or 1-1/2"
2 2"
3 3"

Wetted Parts

A Aluminum
C Cast Iron
S Stainless Steel
H Alloy C
P Polypropylene
K Kynar
G Groundable Acetal
B Aluminum (screen mount)

Non-Wetted Parts

A Aluminum
S Stainless Steel
P Polypropylene
G Groundable Acetal
Z PTFE-coated Aluminum
J Nickel-plated Aluminum
C Cast Iron
Q Epoxy-Coated Aluminum

Diaphragm Material

1 Neoprene
2 Nitrile
3 (FKM) Fluorocarbon
4 EPDM
5 PTFE
6 Santoprene (XL)
7 Hytrel
9 Geolast

Diaphragm Series

R Rugged
D Dome
X Thermo-Matic
T Tef-Matic (2-piece)
B Versa-Tuff (1-piece)
F FUSION (one-piece integrated plate)

Valve Ball Material Valve

1 Neoprene
2 Nitrile
3 (FKM) Fluorocarbon
4 EPDM
5 PTFE
6 Santoprene (XL)
7 Hytrel
8 Polyurethane
9 Geolast
A Acetal
S Stainless Steel

Seat/Valve Seat O-Ring Material

1 Neoprene
2 Nitrile
3 (FKM) Fluorocarbon
4 EPDM
5 PTFE
6 Santoprene (XL)
7 Hytrel
8 Polyurethane
9 Geolast
A Aluminum w/ PTFE O-Rings
S Stainless Steel w/ PTFE O-Rings
C Carbon Steel w/ PTFE O-Rings
H Alloy C w/ PTFE O-Rings
T PTFE Encapsulated Silicone O-Rings

Construction Design

9 Bolted
0 Clamped

Materials

Material Profile:	Operating Temperatures:	
	Max.	Min.
CAUTION! Operating temperature limitations are as follows:		
Conductive Acetal: Tough, impact resistant, ductile. Good abrasion resistance and low friction surface. Generally inert, with good chemical resistance except for strong acids and oxidizing agents.	190°F 88°C	-20°F -29°C
EPDM: Shows very good water and chemical resistance. Has poor resistance to oils and solvents, but is fair in ketones and alcohols.	280°F 138°C	-40°F -40°C
FKM: (Fluorocarbon) Shows good resistance to a wide range of oils and solvents; especially all aliphatic, aromatic and halogenated hydrocarbons, acids, animal and vegetable oils. Hot water or hot aqueous solutions (over 70°F) will attack FKM.	350°F 177°C	-40°F -40°C
Hytrel®: Good on acids, bases, amines and glycols at room temperatures only.	220°F 104°C	-20°F -29°C
Neoprene: All purpose. Resistance to vegetable oils. Generally not affected by moderate chemicals, fats, greases and many oils and solvents. Generally attacked by strong oxidizing acids, ketones, esters and nitro hydrocarbons and chlorinated aromatic hydrocarbons.	200°F 93°C	-10°F -23°C
Nitrile: General purpose, oil-resistant. Shows good solvent, oil, water and hydraulic fluid resistance. Should not be used with highly polar solvents like acetone and MEK, ozone, chlorinated hydrocarbons and nitro hydrocarbons.	190°F 88°C	-10°F -23°C
Nylon: 6/6 High strength and toughness over a wide temperature range. Moderate to good resistance to fuels, oils and chemicals.	180°F 82°C	32°F 0°C

Polypropylene: A thermoplastic polymer. Moderate tensile and flex strength. Resists strong acids and alkali. Attacked by chlorine, fuming nitric acid and other strong oxidizing agents.	180°F 82°C	32°F 0°C
PVDF: (Polyvinylidene Fluoride) A durable fluoroplastic with excellent chemical resistance. Excellent for UV applications. High tensile strength and impact resistance.	250°F 121°C	0°F -18°C
Santoprene®: Injection molded thermoplastic elastomer with no fabric layer. Long mechanical flex life. Excellent abrasion resistance.	275°F 135°C	-40°F -40°C
UHMW PE: A thermoplastic that is highly resistant to a broad range of chemicals. Exhibits outstanding abrasion and impact resistance, along with environmental stress-cracking resistance.	180°F 82°C	-35°F -37°C
Urethane: Shows good resistance to abrasives. Has poor resistance to most solvents and oils.	150°F 66°C	32°F 0°C
Virgin PTFE: (PFA/TFE) Chemically inert, virtually impervious. Very few chemicals are known to chemically react with PTFE; molten alkali metals, turbulent liquid or gaseous fluorine and a few fluoro-chemicals such as chlorine trifluoride or oxygen difluoride which readily liberate free fluorine at elevated temperatures.	220°F 104°C	-35°F -37°C
<i>Maximum and Minimum Temperatures are the limits for which these materials can be operated. Temperatures coupled with pressure affect the longevity of diaphragm pump components. Maximum life should not be expected at the extreme limits of the temperature ranges.</i>		
Metals:		
Alloy C: Equal to ASTM494 CW-12M-1 specification for nickel and nickel alloy.		
Stainless Steel: Equal to or exceeding ASTM specification A743 CF-8M for corrosion resistant iron chromium, iron chromium nickel and nickel based alloy castings for general applications. Commonly referred to as 316 Stainless Steel in the pump industry.		

Ambient temperature range -20 C to +40 C

Process temperature range -20 C to +80 C for models rated as category 1 equipment

-20 c to +100 C for model rated as category 2 equipment

For specific applications, always consult the Chemical Resistance Chart.

In addition, the ambient temperature range and the process temperature range do not exceed the operating temperature range of the applied non-metallic parts as listed in the manuals of the pumps.

AFTERMARKET PARTS

RIGHT PART, RIGHT NOW

Pumper Parts is your single source for parts that fit Air-Operated Double Diaphragm (AODD) pumps

- Wilden®
- ARO®
- Yamada®

Designed to perform equal to or greater than original equipment manufacture.



Phone: (419) 526-7296
 info@pumperparts.com
 www.pumperparts.com

Pumper Parts and its products are not affiliated with any of the original equipment manufacturers referenced herein. All original equipment manufacturers' names, colors, pictures, descriptions and part numbers are used for identification purposes only. Pumper Parts® is a registered trade name of IDEX Corporation. All other trademarks, registered trademarks and product names are the property of their respective owners. Yamada® is a registered trademark of Yamada Corporation. ARO® is a registered trade name of Ingersoll-Rand Company. Wilden® is a registered trade name of Wilden Pump and Engineering Company, a Dover Resources Company.

Performance

E5 1/2" Bolted Metal Rubber and TPE Fitted

Flow Rate

Adjustable to 0-12 gpm (45.4 lpm)

Port Size

Suction 1/2" NPT

Discharge 1/2" NPT

Air Inlet 3/8" NPT

Air Exhaust 3/8" NPT

Suction Lift

Dry 13' (3.9 m)

Wet 22' (6.7 m)

Max Solid Size (Diameter)

. 1/16" (1.6 mm)

Max Noise Level 84 dB(A)

Shipping Weights

Aluminum 11 lbs (3.9 kg)

Stainless 17 lbs (7.7 kg)

Alloy C 17 lbs (7.7 kg)

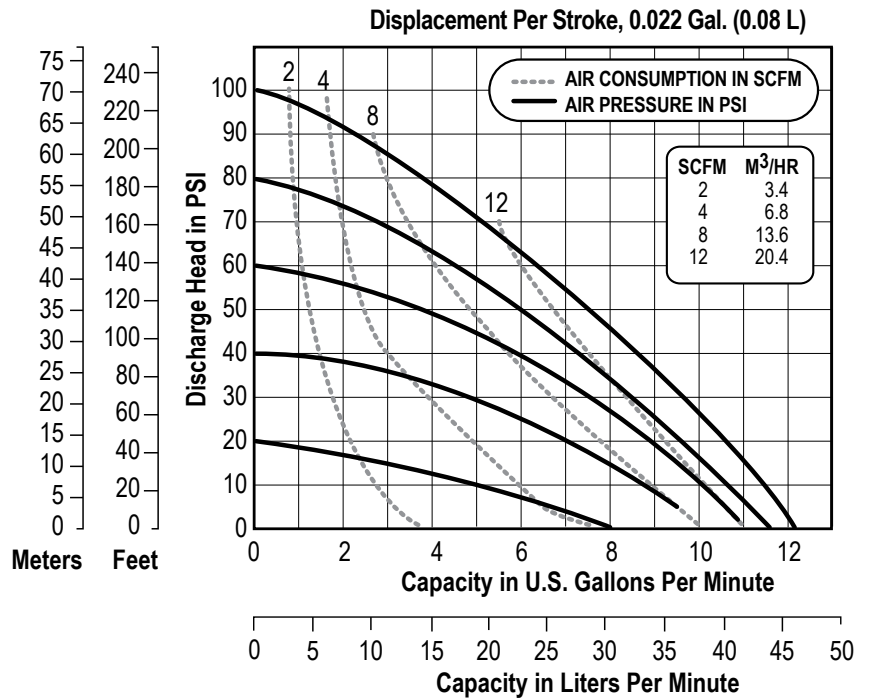

NOTE: Performance based on the following: PTFE fitted pump, flooded suction, water at ambient conditions. The use of other materials and varying hydraulic conditions may result in deviations in excess of 5%.

E5 1/2" Bolted Metal PTFE Fitted

Flow Rate

Adjustable to 0-11 gpm (41.6 lpm)

Port Size

Suction 1/2" NPT

Discharge 1/2" NPT

Air Inlet 3/8" NPT

Air Exhaust 3/8" NPT

Suction Lift

Dry 12' (3.6 m)

Wet 22' (6.7 m)

Max Solid Size (Diameter)

. 1/16" (1.6 mm)

Max Noise Level 87 dB(A)

Shipping Weights

Aluminum 11 lbs (3.9 kg)

Stainless 17 lbs (7.7 kg)

Alloy C 17 lbs (7.7 kg)

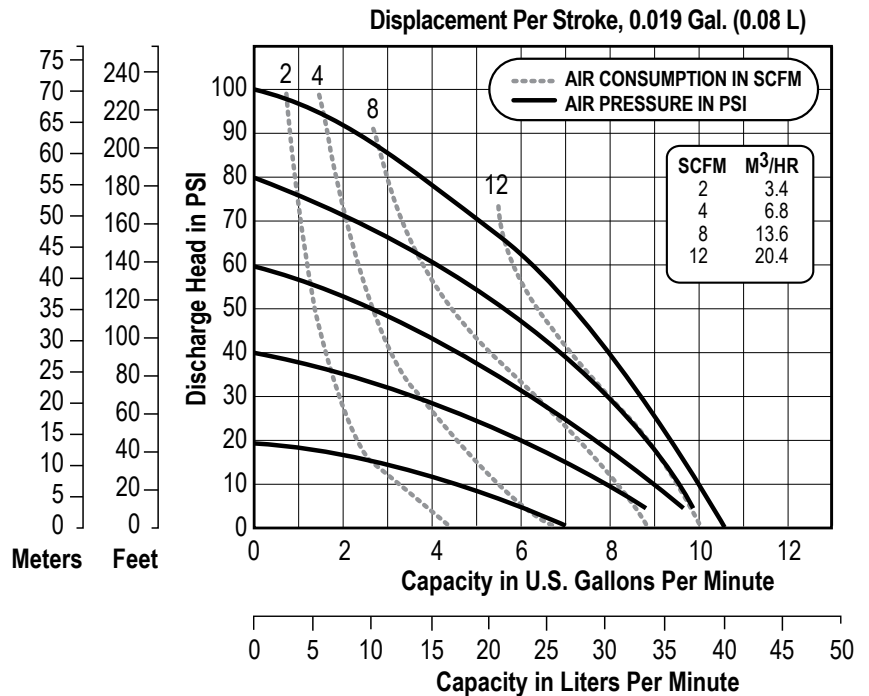

NOTE: Performance based on the following: PTFE fitted pump, flooded suction, water at ambient conditions. The use of other materials and varying hydraulic conditions may result in deviations in excess of 5%.

Dimensional Drawings

E5 Metallic Bolted

Dimensions in inches (mm dimensions in brackets).

The dimensions on this drawing are for reference only. A certified drawing can be requested if physical dimensions are needed.

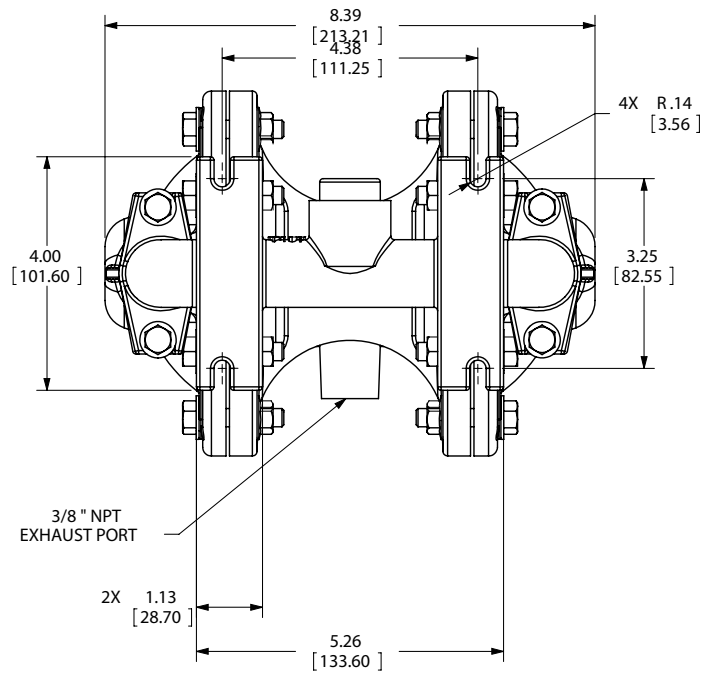
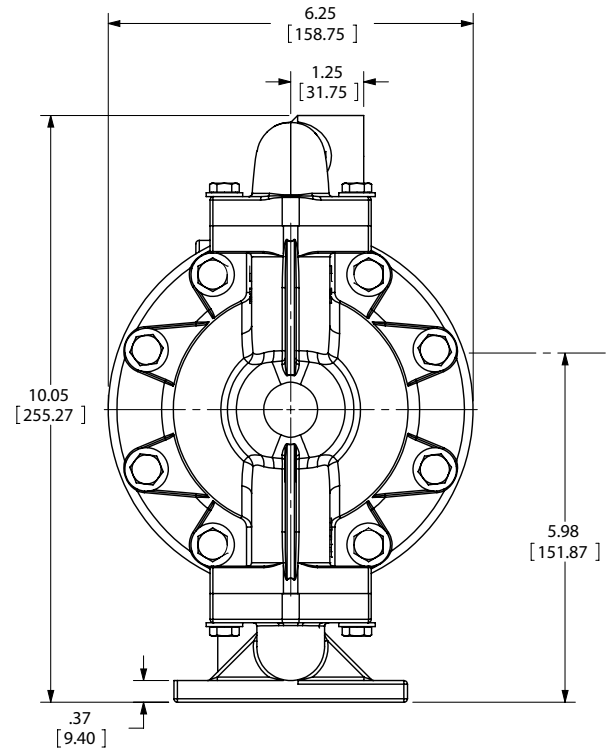
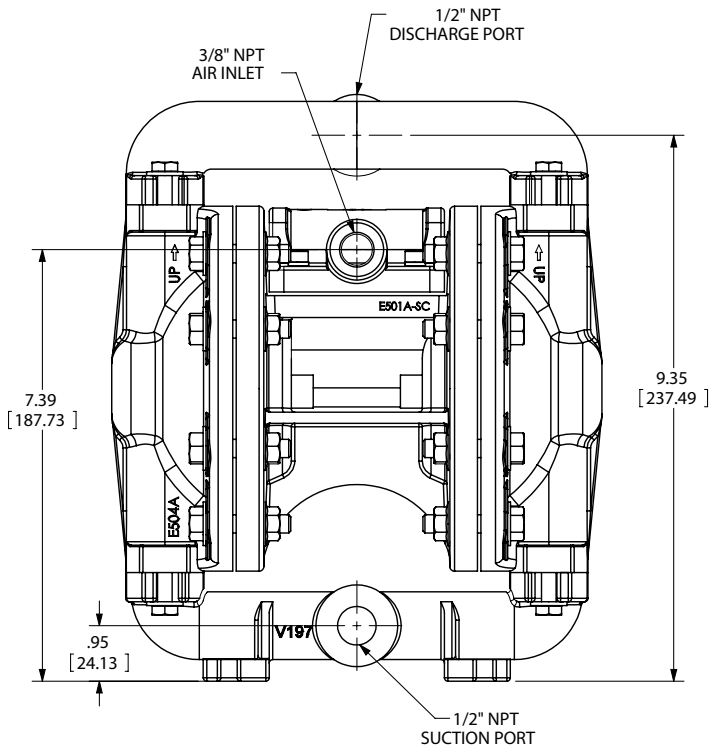

BOTTOM VIEW

Written Warranty

5 - YEAR Limited Product Warranty

Quality System ISO9001 Certified • Environmental Management Systems ISO14001 Certified

Versa-Matic warrants to the original end-use purchaser that no product sold by Versa-Matic that bears a Versa-Matic brand shall fail under normal use and service due to a defect in material or workmanship within five years from the date of shipment from Versa-Matic's factory.

~ See complete warranty at <http://www.versamatic.com/pdfs/VM%20Product%20Warranty.pdf> ~

DECLARATION OF CONFORMITY

DECLARATION DE CONFORMITE • DECLARACION DE CONFORMIDAD • ERKLÄRUNG BEZÜGLICH EINHALTUNG DER VORSCHRIFTEN
DICHIARAZIONE DI CONFORMITÀ • CONFORMITEITSVERKLARING • DEKLARATION OM ÖVERENSSTÄMMELSE
EF-OVERENSSTEMMELSESERKLÆRING • VAATIMUSTENMUKAISUUSVAKUUTUS • SAMSVARSERKLÄRING
DECLARAÇÃO DE CONFORMIDADE

MANUFACTURED BY:

FABRIQUE PAR:
FABRICADA POR:
HERGESTELLT VON:
FABBRICATO DA:
VERVAARDIGD DOOR:
TILLVERKAD AV:
FABRIKANT:
VALMISTAJA:
PRODUSENT:
FABRICANTE:

VERSA-MATIC®
Warren Rupp, Inc.
A Unit of IDEX Corporation
800 North Main Street
P.O. Box 1568
Mansfield, OH 44901-1568 USA
Tel: 419-526-7296
Fax: 419-526-7289



PUMP MODEL SERIES: E1 SERIES, E2 SERIES, E3 SERIES, E4 SERIES, E40 SERIES, E5 SERIES, E7 SERIES, E8 SERIES, RE SERIES AND U2 SERIES

This product complies with the following European Community Directives:

Ce produit est conforme aux directives de la Communauté européenne suivantes:
Este producto cumple con las siguientes Directrices de la Comunidad Europea:
Dieses produkt erfüllt die folgenden Vorschriften der Europäischen Gemeinschaft:
Questo prodotto è conforme alle seguenti direttive CEE:
Dit produkt voldoet aan de volgende EG-richtlijnen:
Denna produkt överensstämmer med följande EU direktiv:
Versa-Matic, Inc., erklærer herved som fabrikant, at ovennævnte produkt er i overensstemmelse med bestemmelserne i Direktive:
Tämä tuote täyttää seuraavien EC Direktiivien vaatimukset:
Dette produkt oppfyller kravene til følgende EC Direktiver:
Este produto está de acordo com as seguintes Directivas comunitárias:

2006/42/EC
on Machinery, according
to Annex VIII

This product has used the following harmonized standards to verify conformance:

Ce matériel est fabriqué selon les normes harmonisées suivantes, afin d' en garantir la conformité:
Este producto cumple con las siguientes directrices de la comunidad europea:
Dieses produkt ist nach folgenden harmonisierten standards gefertigt worden, die übereinstimmung wird bestätigt:
Questo prodotto ha utilizzato i seguenti standards per verificare la conformità:
De volgende geharmoniseerde normen werden gehanteerd om de conformiteit van dit produkt te garanderen:
För denna produkt har följande harmoniserande standarder använts för att bekräfta överensstämmelse:
Harmoniserede standarder, der er benyttet:
Tässä tuotteessa on sovellettu seuraavia yhdenmukaistettuja standardeja:
Dette produkt er produsert i overstemmelse med følgende harmoniserte standarder:
Este produto utilizou os seguintes padrões harmonizados para varificar conformidade:

EN 809

AUTHORIZED/ APPROVED BY:

Approuve par:
Aprobado por:
Genehmigt von:
approvato da:
Goedgekeurd door:
Underskrift:
Valtuutettuna:
Bemyndiget av:
Autorizado Por:

David Roseberry
Dave Roseberry
Engineering Manager

DATE: August 10, 2011

FECHA:
DATUM:
DATA:
DATO:
PÄIVÄYS:



VMQR 044FM

05/27/2010 REV 05



WWW.VERSAMATIC.COM

E5mdl2ds-ATEX-rev1211

Model E5 Metallic Bolted • 5

DECLARATION OF CONFORMITY WITH ATEX 95 DIRECTIVE



Date of Issue: 22 April, 2008

Reference No: SH071304-ATEX-01P and
HS032204-ATEX-01P

Quality System Registration No: ISO 9001-2000

Directive: 94/9/EC 23 March 1994 Annex VIII

Conforming Apparatus: Air-Operated Metal
Double Diaphragm Pumps for Use In Potentially
Explosive Atmospheres

Hazardous Location Applied: 1. II 3/2GD c T5
T5 fluids up to 95° C

2. I M2 c
fluids up to 95° C

Manufacture: Warren Rupp, Inc., A Unit of IDEX Corporation
800 North Main Street, P.O. Box 1568
Mansfield, OH 44901-1568
USA.

On File With: LCIE
33, avenue du Général Leclerc
F 92260 Fontenay-aux-Roses
FRANCE

Harmonized Standards Applied: BS EN 13463-1:2001 Non-Electrical Equipment
Potentially Explosive Atmospheres-Part 1 Basic
Methods and Requirements
prEN 13463-5 Non-Electrical Equipment for
Potentially Explosive Atmospheres-Part 5
Protection by Constructional Safety

We hereby certify that the above apparatuses described above conforms with the protection requirements of Council Directive 94/9/EC of 23 March 1994 Annex VIII on the approximation of the laws of the Member States Concerning Equipment and Protective Systems Intended for use in Potentially Explosive Atmospheres

Dave Roseberry
Engineering Manager

DATE/OF REVISION/TITLE:
27 May 2010

VERSA-MATIC®

IDEX
FLUID & METERING

DECLARATION OF CONFORMITY WITH ATEX 95 DIRECTIVE



Date of Issue: 22 April, 2008

Reference No: SH071304-ATEX-01P and
HS032204-ATEX-01P Page 2 of 2

Quality System Registration No: ISO 9001-2000

Equipments:

1. Elima-Matic Series metal pumps for
II 3/2GD c T5
2. Elima-Matic Series Cast Iron or Stainless Steel
pumps with Stainless Steel air center sections
for I M2 c

VERSA-MATIC®

IDEX
FLUID & METERING