

E4

1-1/2" Sanitary Pump

Specifications

Flow Rate adjustable to . . . 0-60 gpm (227 lpm)

Port Size

Inlet and Discharge 1.5" Tri-Clamp®

Air Inlet 0.50" NPT

Air Exhaust 0.75" NPT

Suction Lift

PTFE 10' Dry/20' Wet (3.05m/6.10m)

Max. Particle Size (Dia.) 0.375" (9.53mm)

Surface Finish . . 32 micro-inch (0.8 micrometer)

Shipping Weight

316 Stainless Steel 75 lbs (34.09 kg)



Performance

Displacement Per Stroke, 0.31 Gal. (0.11 L)

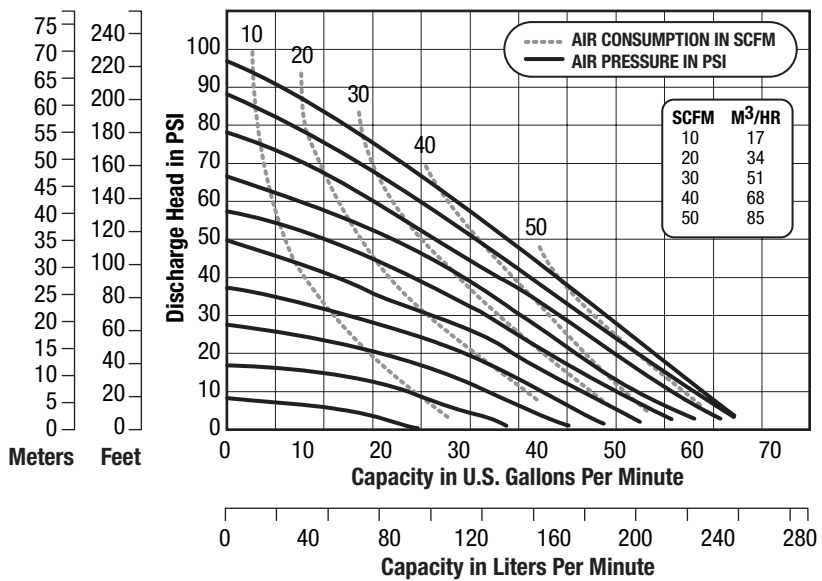

NOTE: For E4 pumps fitted with PTFE diaphragms, reduce water discharge figures by 20%. Suction lift is reduced to 10' (3.05m) dry and 20' (6.10m) wet.

CAUTION: Do not exceed 125 psig (8.5 bars) air supply or liquid pressure.

Dimensions

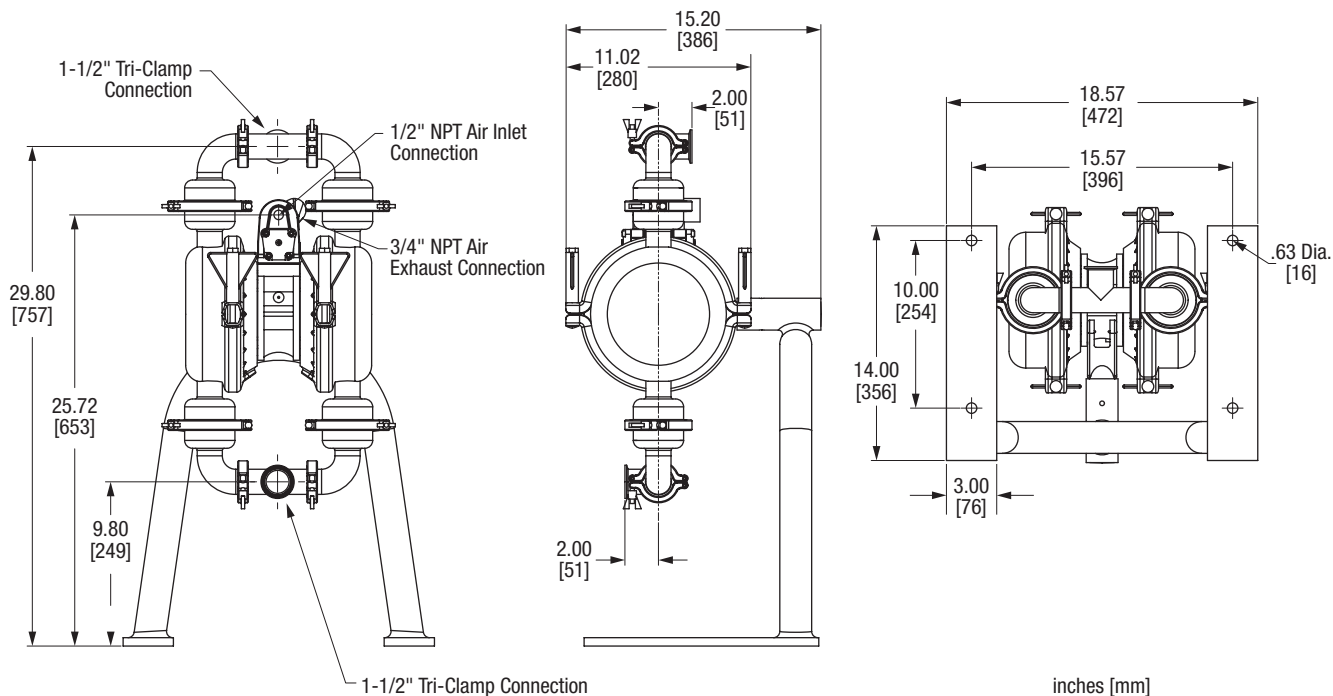

Consult factory for certified drawings.