

2" Ultra-Matic™ Bolted Metallic Pumps

Vertical and Optional Horizontal Discharge Models

U2

- Stainless Steel
- Hastelloy C
- Cast Iron

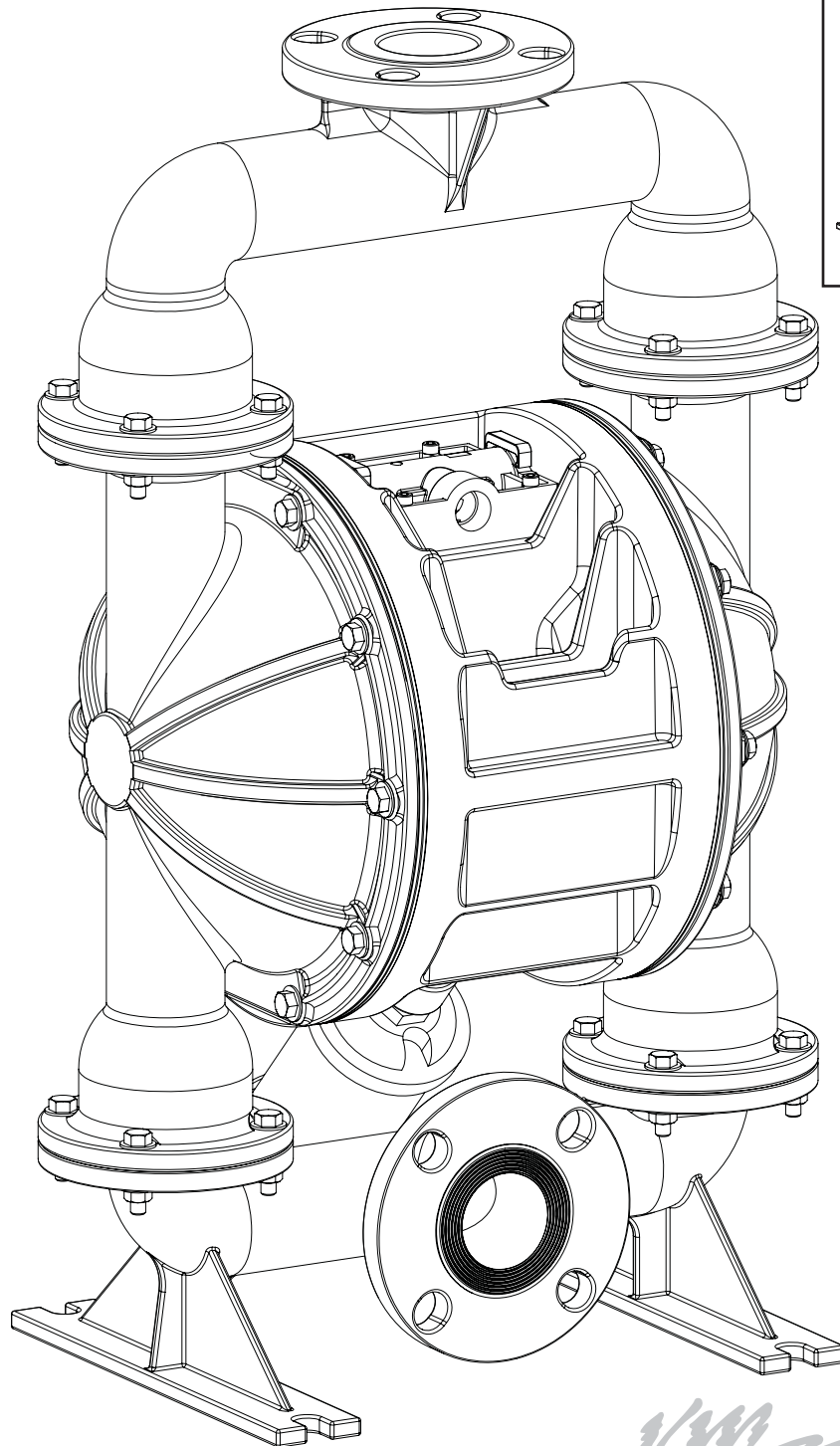
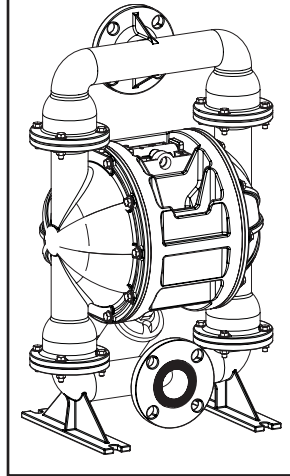

VERSA-MATIC®

WARNINGS, CAUTIONS & NOTICES

Please read all cautions, warnings and notes completely before installation and start-up. It is the responsibility of the purchaser to retain

this manual for reference. Failure to comply with the recommendations stated in this manual may damage the pump and void the factory warranty.

WARNINGS



To prevent static sparking the pump, piping, valves, and containers must be grounded. Fire or explosion can occur when handling flammable fluids and whenever discharge of static electricity is a hazard.



Pump exhaust may contain contaminants that can cause serious injury. Take precautions to pipe exhaust away from work area if pumping chemicals, hazardous or flammable materials.

CAUTIONS



You must check the tightness of all hardware prior to installation.



Do not exceed the maximum inlet air pressure as stated on the pump model tag.



Maximum temperature limits are based on mechanical stress only. Certain chemicals will significantly reduce maximum safe operating temperatures. For chemical compatibility and temperature limits please refer to the Chemical Resistance Guide.



Disconnect the compressed air line to the pump and allow all air pressure to bleed from pump prior to performing any maintenance on the pump. Disconnect all intake, discharge and air lines. Drain the pump and dispose of fluid into a suitable container.



Check temperature limits for all wetted components when choosing pump materials. Temperature limits may vary depending on the material.



All operators of the equipment should be properly trained to ensure safe working practices.



The process fluid and cleaning fluids must be chemically compatible with all wetted pump components. Please refer to the Chemical Resistance Guide for additional information.



Never allow the piping system to be supported by the pump manifolds or valve housing. These components are not designed to support structural weight and pump failure may result..



Thoroughly flush pump before installing into process lines. FDA and sanitary approved pumps should be cleaned or sanitized before use.



Noise levels can exceed 85 dBA. **Always wear ear and eye protection when operating or repairing pumps.**

NOTICES



Blow out air line for at least 15 seconds before attaching to pump to make sure that all debris is removed. Use an in-line air filter.



Compressed air should not be applied to the exhaust port. If this happens the pump will not function.



Clamp style pumps fitted with PTFE or XLTPPE come standard from the factory with expanded PTFE liquid chamber gaskets. **PTFE gaskets cannot be reused.**



Before disassembly of clamp band pumps, mark a line from each liquid chamber to its corresponding air chamber. This will ensure proper alignment when reassembling.



Tighten both outer pistons at the same time to ensure a tight fit when installing PTFE diaphragms. See torque settings for additional details.



The pump does not require continuous lubrication.

VERSA-MATIC® MODEL IDENTIFICATION CODES

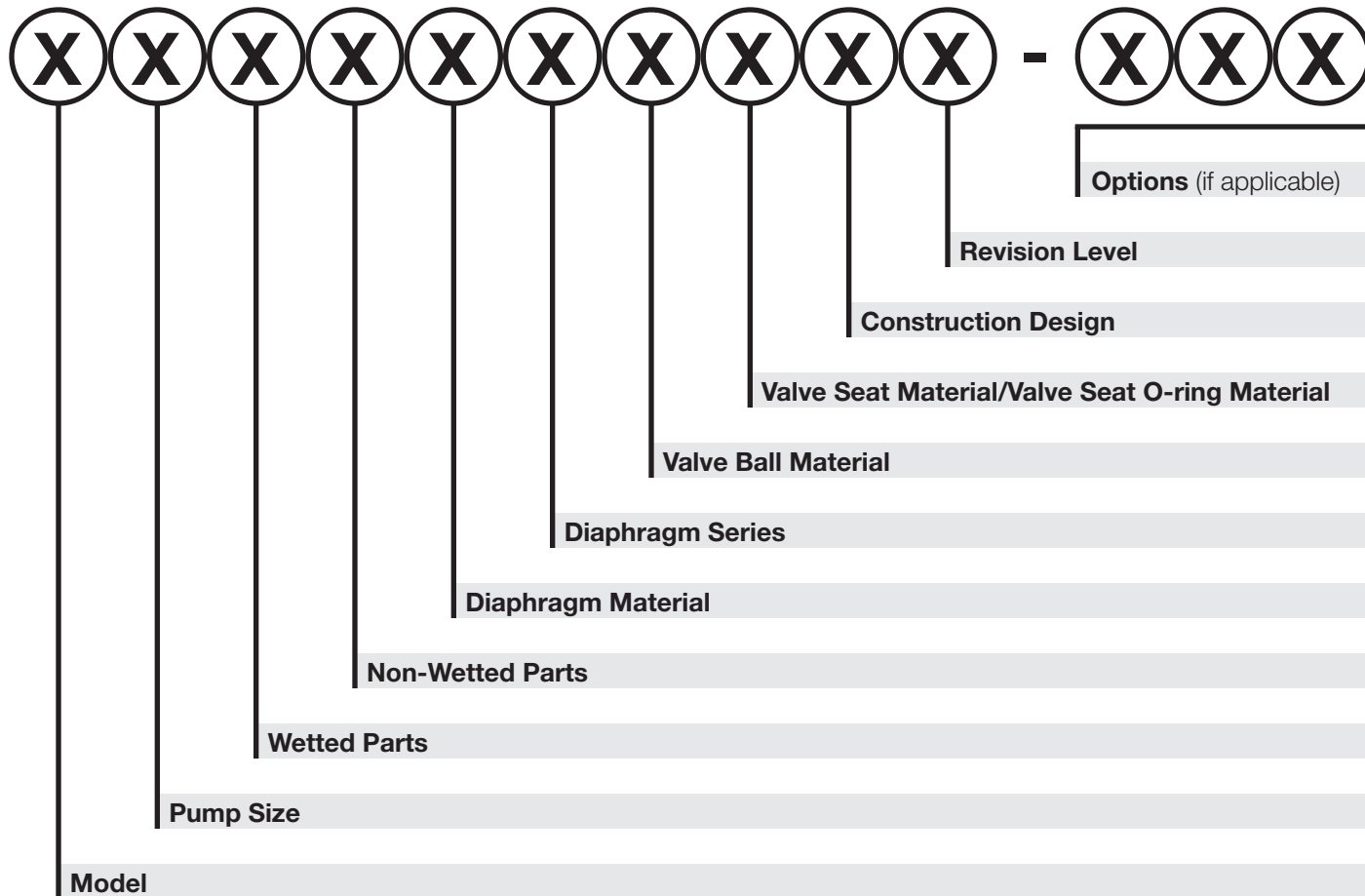

Model

E Elima-Matic
U Ultra-Matic
V V-Series

Pump Size

6 1/4"
8 3/8"
5 1/2"
7 3/4"
1 1"
4 1-1/4" or 1-1/2"
2 2"
3 3"

Wetted Parts

A Aluminum
C Cast Iron
S Stainless Steel
H Hastelloy C
P Polypropylene
K PVDF
G Groundable Acetal
B Aluminum (screen mount)

Non-Wetted Parts

A Aluminum
S Stainless Steel
P Polypropylene
G Groundable Acetal
Z PTFE-coated Aluminum
J Nickel-plated Aluminum
C Cast Iron
Q Epoxy-Coated Aluminum

Diaphragm Material

1 Neoprene
2 Buna-N
3 (FKM) Fluorocarbon
4 Nordel
5 PTFE
6 XL
7 Hytrel
9 Geolast

Diaphragm Series

R Rugged
D Dome
X Thermo-Matic
T Tef-Matic (2-piece)
B Versa-Tuff (1-piece)
F FUSION (one-piece integrated plate)

Valve Ball Material

1 Neoprene
2 Buna-N
3 (FKM) Fluorocarbon
4 Nordel
5 PTFE
6 XL
7 Hytrel
8 Polyurethane
9 Geolast
A Acetal
S Stainless Steel

Valve Seat/Valve Seat O-ring Material

1 Neoprene
2 Buna-N
3 (FKM) Fluorocarbon
4 Nordel
5 PTFE
6 XL
7 Hytrel
8 Polyurethane
9 Geolast
A Aluminum w/ PTFE O-rings
S Stainless Steel w/ PTFE O-rings
C Carbon Steel w/ PTFE O-rings
H Hastelloy C w/ PTFE O-rings
T PTFE Encapsulated Silicone O-rings

Construction Design

9 Bolted
0 Clamped

U2B SPECIFICATIONS & PERFORMANCE

Specifications

	English	Metric
Flow rate		
adjustable to	0-170 gpm	0-644 lpm
Port size		
Inlet and Outlet	2" ANSI/DIN #50 Flange	
Air inlet	0.50" NPTF	
Air exhaust	0.75" NPTF	
Suction lift* (dry)		
Rubber	20'	6.10 m
PTFE	10'	3.05 m
Max. particle size		
Diameter	0.25"	6 mm
Shipping weight		
Cast Iron	115 lbs	52 kg
Hastelloy C	123 lbs	56 kg
Stainless Steel	115 lbs	52 kg



Performance

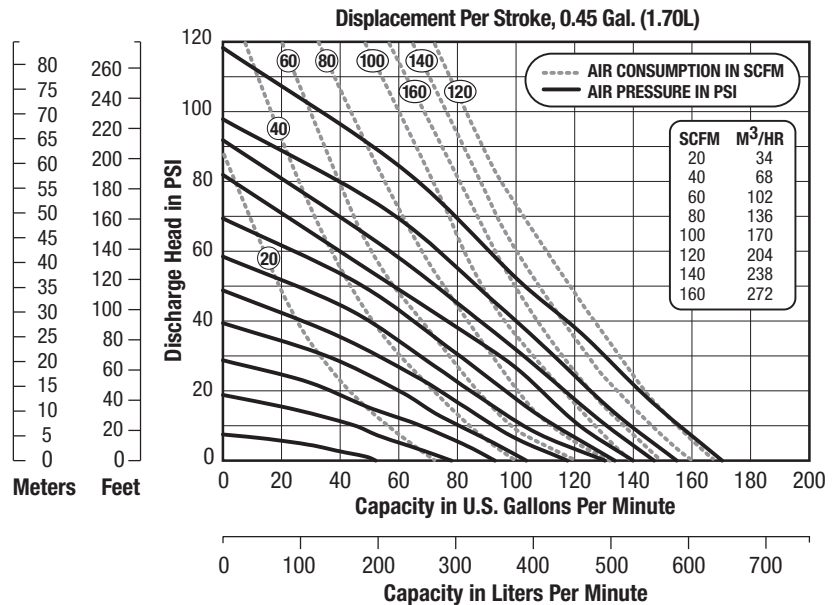

NOTE: For U2 pumps fitted with PTFE diaphragms, reduce water discharge figures by 20%. Suction lift is reduced to 10' (3.05m) dry and 20' (6.10m) wet.

CAUTION: Do not exceed 125 psig (8.5 bars) air supply or liquid pressure.

Dimensions

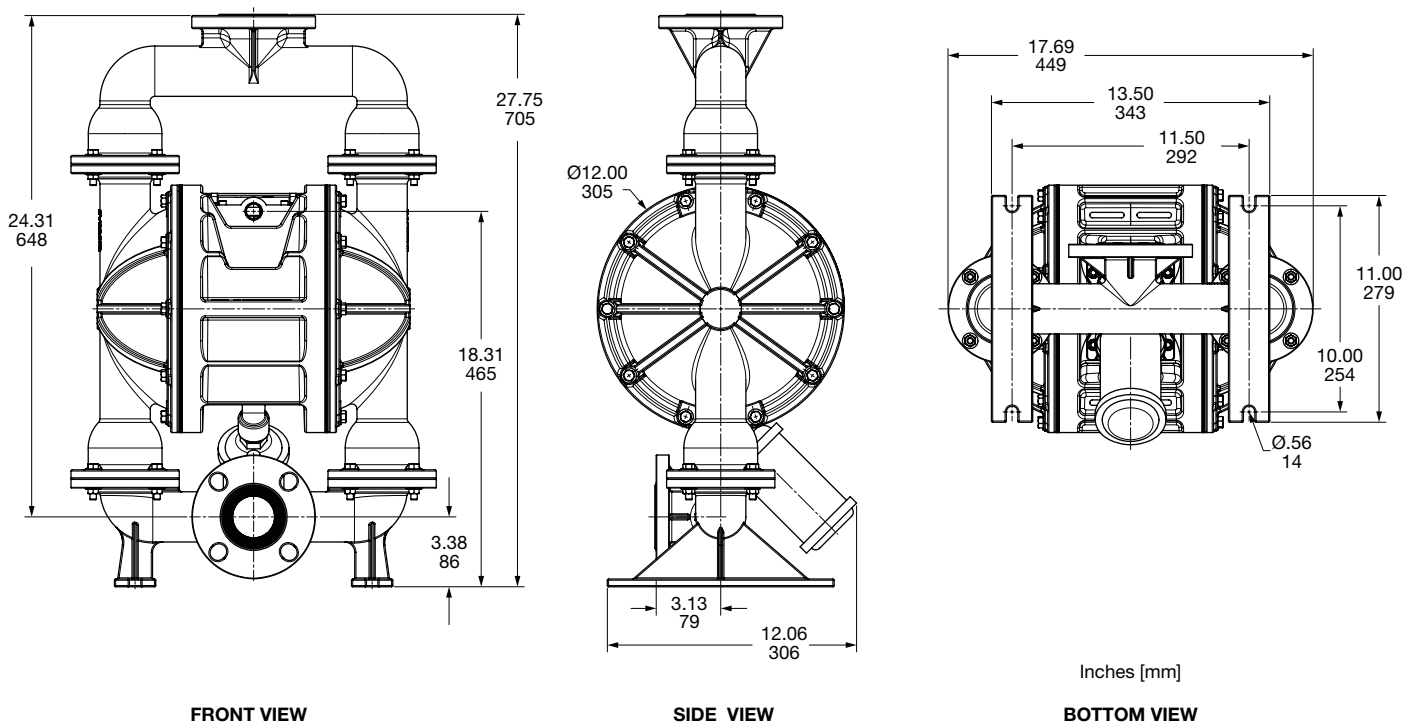

Consult factory for certified drawings.

U2B SPECIFICATIONS & PERFORMANCE

Specifications

	English	Metric
Flow rate		
adjustable to	0-170 gpm	0-644 lpm
Port size		
Inlet and Outlet	2" ANSI/DIN #50 Flange	
Air inlet	0.50" NPTF	
Air exhaust	0.75" NPTF	
Suction lift* (dry)		
Rubber	20'	6.10 m
PTFE	10'	3.05 m
Max. particle size		
Diameter	0.25"	6 mm
Shipping weight		
Cast Iron	115 lbs	52 kg
Hastelloy C	123 lbs	56 kg
Stainless Steel	115 lbs	52 kg



Performance

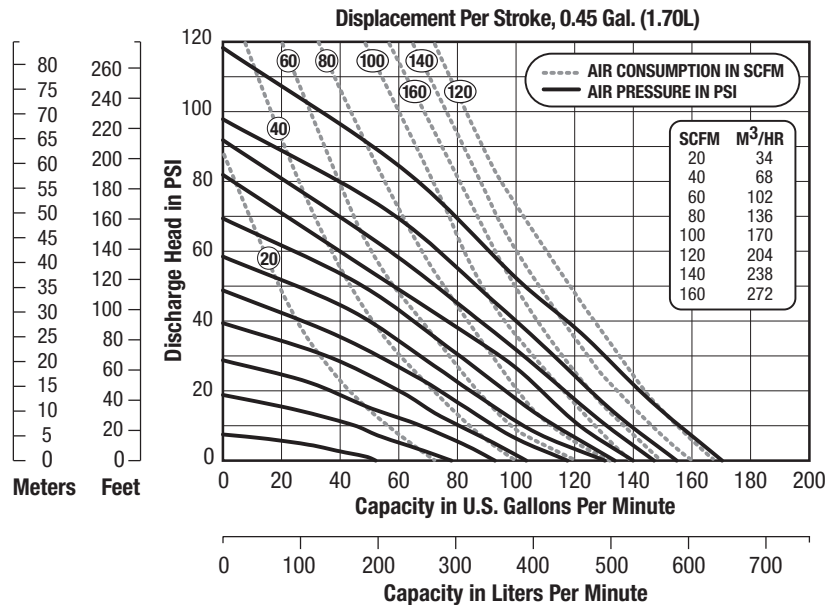

NOTE: For U2 pumps fitted with PTFE diaphragms, reduce water discharge figures by 20%. Suction lift is reduced to 10' (3.05m) dry and 20' (6.10m) wet.

CAUTION: Do not exceed 125 psig (8.5 bars) air supply or liquid pressure.

Dimensions

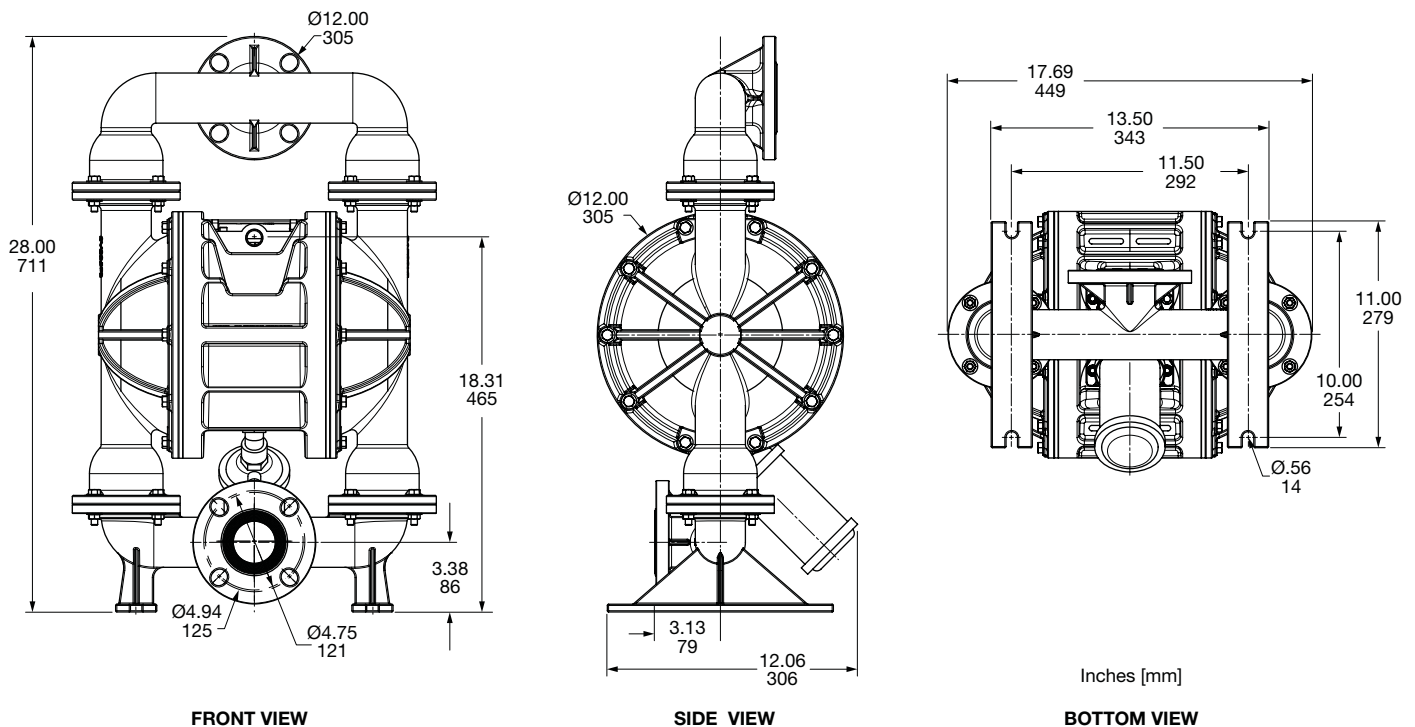

Consult factory for certified drawings.

INSTALLATION, OPERATION & MAINTENANCE

Installation

The pump should be mounted in a vertical position. In permanent installations, the pump should be attached to plant piping using a flexible coupling on both the intake and discharge connections to reduce vibration to the pump and piping. To further reduce vibration, a surge suppressor next to the pump may be used.

Suction pipe size should be at least the same diameter as the inlet connection size, even larger if highly viscous fluid is to be pumped. If suction hose is used, it must be of a non-collapsible reinforced type. Discharge piping should be of at least the same diameter as the discharge connection.

It is critical, especially on the suction side of the pump, that all fittings and connections are air tight or pumping efficiency will be reduced and priming will be difficult.

Make certain the air supply line and connections and compressor are capable of supplying the required pressure and volume of air to operate the pump at the desired flow rate. The quality of the compressed air source should be considered. Air that is contaminated with moisture and dirt may result in erratic pump performance and increased maintenance cost as well as frequent process "down time" when the pump fails to operate properly.

Pump Operation

The pump is powered by compressed air. Compressed air is directed to the pump air chamber by the main air valve. The compressed air is

separated from the fluid by a membrane called a diaphragm. The diaphragm in turn applies pressure on the fluid and forces it out of the pump discharge. While this is occurring, the opposite air chamber is de-pressurized and exhausted to atmosphere and fluid is drawn into the pump suction. The cycle again repeats, thus creating a constant reciprocating action which maintains flow through the pump. The flow is always in through the bottom suction connection

and out through the top discharge connection. Since the air pressure acts directly on the diaphragms, the pressure applied to the fluid roughly approximates the air supply pressure supplied to the main air valve.

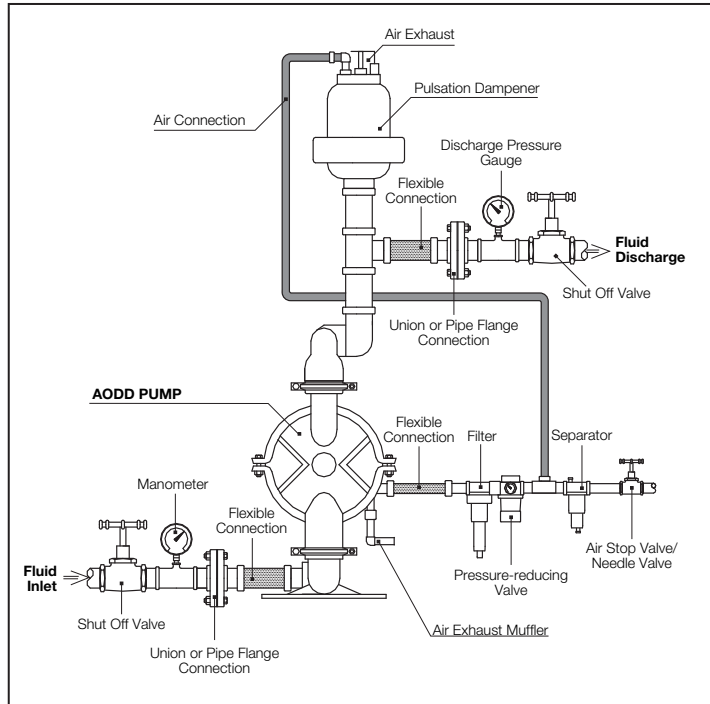

Recommended Piping Connections

Pump Size	Minimum Air Line Size	Minimum Suction Line Size
1/4"	1/4"	1/4"
3/8"	1/4"	3/8"
1/2"	1/2"	1/2"
1"	1/2"	1"
1-1/2"	1/2"	1-1/2"
2"	1/2"	2"
3"	3/4"	3"

TROUBLESHOOTING

Symptom	Potential Cause(s)	Recommendation(s)
Pump cycles once	<ol style="list-style-type: none"> 1 Incorrect pilot o-ring placement 2 Inner diaphragm plate installed backwards 3 Deadhead (system pressure meets or exceeds air supply pressure) 4 Air valve or center block gaskets installed incorrectly 	<ol style="list-style-type: none"> 1 Reinstall pilot o-rings in correct positions 2 Reinstall inner diaphragm plate correctly 3 Check system for pressure ratio to pump 4 Install gaskets with holes properly aligned
Pump will not operate	<ol style="list-style-type: none"> 1 Pump is over lubricated 2 Lack of air (line size, PSI, CFM) 3 Worn o-rings 4 Wrong type of lubrication (attack on o-rings) 5 Debris in air valve 6 Clogged manifolds 7 Incorrect o-ring placement 8 Deadhead (system pressure meets or exceeds air supply pressure) 	<ol style="list-style-type: none"> 1 Set lubricator on lowest possible setting or remove <ul style="list-style-type: none"> • Elima-Matic is designed for lube free operation 2 Check the air line size and length, compressor capacity (HP vs. cfm required) 3 Replace o-rings 4 Check compatibility of o-rings with lubrication 5 Clean air valve/filter 6 Clean suction or discharge manifolds/piping 7 Reinstall o-rings in correct position 8 Increase air supply pressure
Pump cycles and will not prime or flow	<ol style="list-style-type: none"> 1 Cavitation on suction side 2 Valve ball(s) not seating properly or sticking 3 Valve ball(s) missing (pushed into chamber) 4 Valve ball(s)/seat(s) damaged or attacked by product 5 Clogged suction line 	<ol style="list-style-type: none"> 1 Check suction condition (move pump closer to product) 2 Clean out around valve ball cage and valve seat area <ul style="list-style-type: none"> • Replace valve ball or valve seat if damaged • Use heavier valve ball material 3 Worn valve ball or valve seat <ul style="list-style-type: none"> • Worn fingers in valve ball cage (replace part) 4 Check Chemical Resistance Guide for compatibility 5 Clean suction manifold and/or piping
Pump running sluggish/stalling	<ol style="list-style-type: none"> 1 Over lubrication 2 Icing 3 Clogged manifolds 4 Deadhead (system pressure meets or exceeds air supply pressure) 5 Cavitation on suction side 6 Lack of air (line size, PSI, CFM) 	<ol style="list-style-type: none"> 1 Set lubricator on lowest possible setting or remove <ul style="list-style-type: none"> • Elima-Matic is designed for lube free operation 2 Clean or replace exhaust muffler 3 Clean manifolds to allow proper air flow 4 Check system to locate deadhead (equilibrium) <ul style="list-style-type: none"> • Increase air supply pressure 5 Check suction (move pump closer to product) 6 Check the air line size, length, compressor capacity
Product leaking through exhaust	<ol style="list-style-type: none"> 1 Diaphragm failure, or diaphragm plates loose 2 Diaphragm stretched around center hole or bolt holes 3 Excessive air supply pressure 	<ol style="list-style-type: none"> 1 Replace diaphragms, check for damage and ensure diaphragm plates are tight 2 Check for excessive inlet pressure or air pressure <ul style="list-style-type: none"> • Tighten bolts to recommended torque 3 Check Operating Manual for recommendations
Premature diaphragm failure	<ol style="list-style-type: none"> 1 Cavitation 2 Excessive flooded suction pressure 3 Misapplication (chemical/physical incompatibility) 4 Wrong type of lubrication (attack on air side) 5 Incorrect diaphragm plates or plates on backwards 6 Incorrect shaft with corresponding elastomer 7 Start up at full air pressure 	<ol style="list-style-type: none"> 1 Enlarge pipe diameter on suction side of pump 1,2 Move pump closer to product <ul style="list-style-type: none"> • Raise pump/place pump on top of tank to reduce inlet pressure 2 Add accumulation tank or pulsation dampener as close to the pump as possible 3,4 Consult Chemical Resistance Chart for compatibility with products, cleaners, temperature limitations and lubrication 5,6 Check Operating Manual to check for correct part and installation 7 Start up pump slowly (manually or with Smart Start)
Breaking and bending shafts	<ol style="list-style-type: none"> 1 Build up of solids in water chamber 2 Loose diaphragm plates 	<ol style="list-style-type: none"> 1 Flush pump, start pump slow 2 Tighten diaphragm plates when replacing diaphragms

U2B PARTS LIST

AIR VALVE ASSEMBLY

Item	Description	Qty	Standard: Polypropylene
	Air Valve Assembly (Includes items 1-10)	1	E200
1	Valve Body	1	E200A
2	Valve Spool Assembly	1	E200B ASY (Includes U-Cups)
3	Valve Spool U-Cup	2	P98-104A
4	End Cap Assembly	2	E500D ASY (Includes O-Rings)
5	End Cap Staple	2	E500F
6	Staple Retainer	2	E200L
7	Air Diverter	1	E200G
8	Valve Insert	1	E200H
9	Valve Gasket	1	E200J
10	Valve Cap Screw	4	P24-209

AIR END ASSEMBLY

Item	Description	Qty	Standard: Polypropylene/Aluminum
15	Center Section	1	E201B
16	Bushing	2	E201MB
17	Pilot Shaft	1	E203A
18	Pilot Shaft Spacer	5	P24-106P
19	Pilot Shaft O-Ring	6	P24-107
20	Stop Nut	2	P24-108
21	Shaft Retainer – Left	1	E201B-L ASY (Includes O-Rings)
22	Shaft Retainer – Right (not shown)	1	E201B-R ASY (Includes O-Rings)
23	Exhaust Sleeve O-Ring	2	E201M-1
24	Shaft Retainer Screw	2	10-050
25	Exhaust Valve	2	E202 ASY
26	Shaft Retainer O-Ring	2	E201B-5
27	Retainer Plate Seal	2	E201B-3
28	Muffler Plate	1	E201H
29	Muffler Plate Gasket	1	E200J-1
30	Muffler Plate Cap Screw	4	E201G
31	Muffler Elbow	1	PE201N
32	Muffler	1	V20AEM

DIAPHRAGM ASSEMBLY

Item	Description	Qty	DOME	PTFE Bonded	PTFE 2-Piece
40	Main Shaft	1	P24-103	P24-102	P24-102
42	Inner Diaphragm Plate	2	V226B SV226B V226BTC V226BNP	V221T SV221TI V221TITC V221TINP	V221TI SV221TI V221TITC V221TINP
43	Outer Diaphragm Plate	2	SVB226 HV226B	SV221TO HV221TO	SV221TO HV221TO
45	Diaphragm	2	V227BN V227N V227ND V227VT V227TPEXL V227TPEFG	V227TX	V227
46	Back-up Diaphragm	2	N/A	N/A	V227TFB

WET END ASSEMBLY

Item	Description	Qty	Std: Stainless	Option 1: Cast Iron	Option 2: Hastelloy
50	Water Chamber	2	SV235FB	WV235FB	HV235FB
51	Water Chamber Bolt	12	SV185A	SV185A	SV185A
52	Water Chamber Washer	20	SV189C	SV189C	SV189C
53	Valve Seat	4	V240BN V240CS V240N V240ND V240TF V240TPEFG V240TPEXL V240VT SV240 HV240		
54	Valve Seat O-Ring (not shown)	8	V240T (USE WITH V240CS, SV240 AND HV240 SEATS)		
55	Valve Ball	4	V241BN V241N V241ND V241P V241TF V241TPEXL V241TPEFG V241VT		
Port Option 1: Vertical Discharge					
56	Discharge Manifold	1	SV236FB	WV236FB	N/A
57	Inlet Manifold	1	SV237FB	N/A	N/A
58	Manifold Bolt	16	SV189D	N/A	N/A
59	Manifold Washer	16	SV189C	N/A	N/A
60	Manifold Nut	16	SV185B	N/A	N/A
Port Option 2: Horizontal					
61	Discharge Manifold	1	SV236F-BH	SV236FB-H	HV236FB-H
62	Inlet Manifold	1	SV237FB-H	WV237FB-H	HV237FB-H
63	Manifold Bolt	16	SV189D	SV189D	SV189D
64	Manifold Washer	16	SV189C	SV189C	SV189C
65	Manifold Nut	16	SV185B	SV185B	SV185B

U2B EXPLODED VIEW

Optional Horizontal Discharge

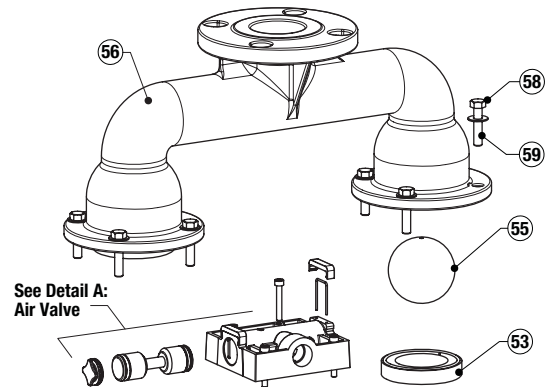
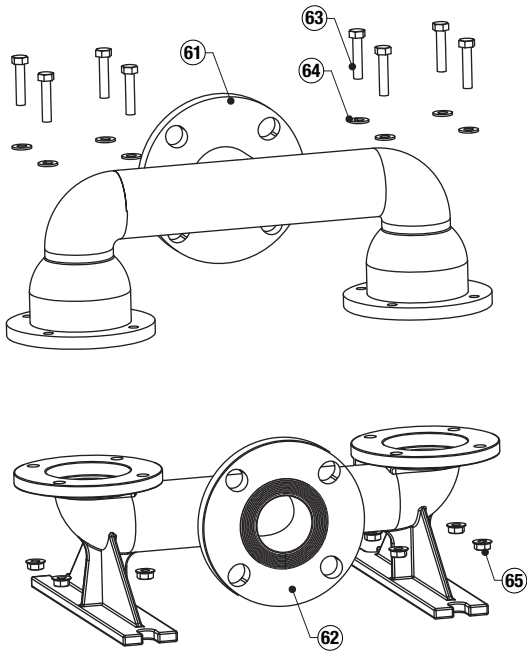

Shown with Versa-Dome Diaphragms
 See Detail D for PTFE Bonded Diaphragms
 See Detail E for PTFE 2-Piece Diaphragms

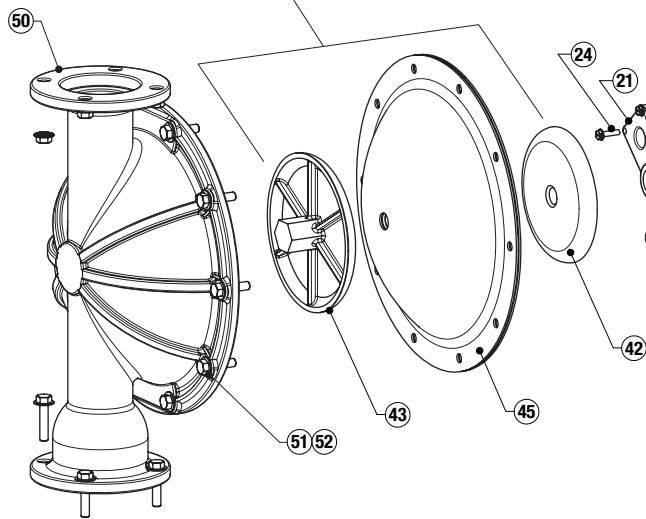

See Detail C:
 Exhaust Valves

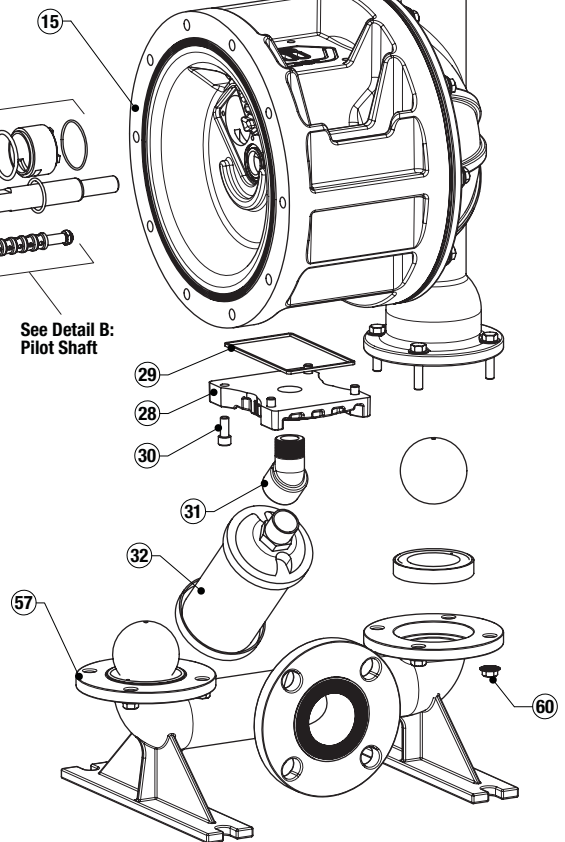

Torque Settings

Manifold Bolts	25 ft-lbs (34 N-m)
Water Chamber Bolts	25 ft-lbs (34 N-m)
Diaphragm Plates — Rubber	65 ft-lbs (88 N-m)
Diaphragm Plates — PTFE	65 ft-lbs (88 N-m)
Air Valve Cap Screws	25 in-lbs (2.8 N-m)
Muffer Plate Cap Screws	30 in-lbs (3.4 N-m)

U2B DETAIL VIEWS

Detail A

Air Valve Assembly

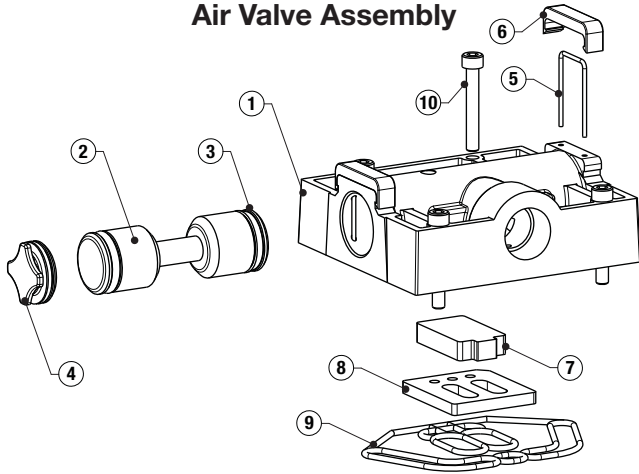

Detail B

Pilot Shaft Assembly

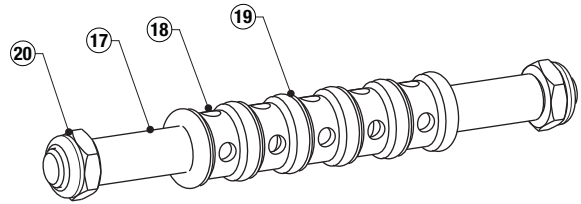

Detail C

Exhaust Valve Assembly

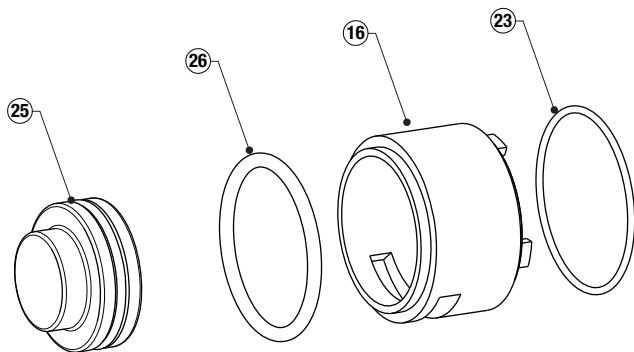

Detail D

PTFE Bonded Diaphragms

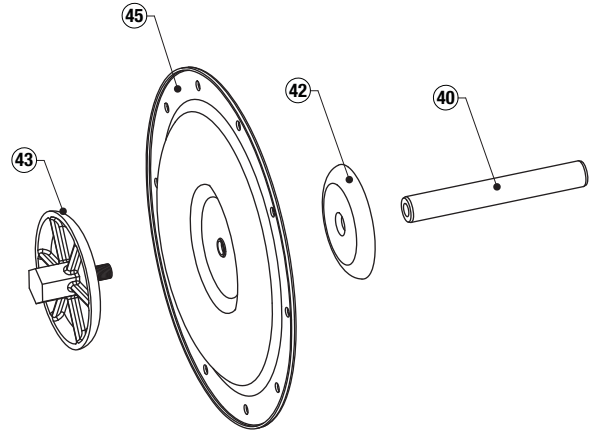

Detail E

PTFE 2-Piece Diaphragms

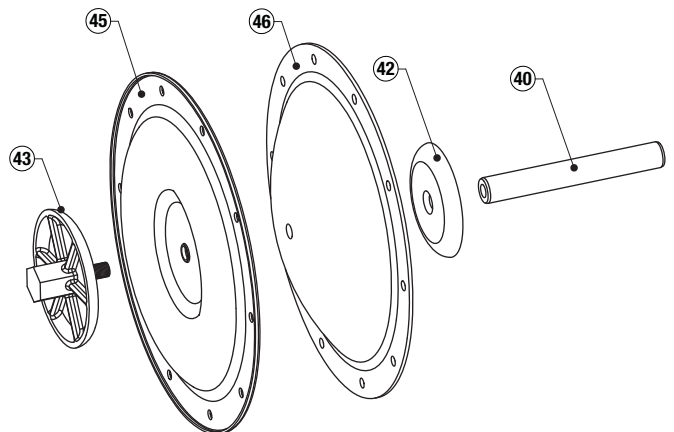

MATERIALS, TEMPERATURE LIMITS & COMPATIBILITY

Materials of Construction — Pumps

MODEL	Acetal®	Aluminum	Cast Iron	Hastelloy C	Polypropylene	PVDF	Stainless Steel
E6 (1/4")	■				■	■	
E8 (3/8")					●	●	
E5 (1/2")	●	●		●	●▲	●▲	●
E7 (3/4")		●					
E1 (1")		●		●	●▲	●▲	●
E4 (1-1/4" – 1-1/2")		■	■	●■	●	●	●■
E2 (2")		●■	●■	●■	●	●	●■▲▼
E2-FV (2")		■					
E3 (3")		●■	■	●■	●	●	●■

● Bolted Construction ■ Clamped Construction ▲ Split Manifold Model Available ▼ High Pressure Model Available

Diaphragms, Valve Balls, Valve Seats & Valve Seat O-rings

	Aluminum	Buna-N	PVDF	Neoprene	EPDM	Polypropylene	Polyurethane	316 Stainless Steel	PTFE			Encapsulated Silicone	Thermoplastics		(FKM) Fluorocarbon
									Tef-Matic™	Versa-Tuff™	FUSION™		Santoprene (TPE XL)	FDA Hytrel®	
ELASTOMERS															
DIAPHRAGMS			●		●	●				●	●		●	●	●
VALVE BALLS			●		●	●		●	●	●			●	●	●
VALVE SEATS		●	●	●	●	●	●	●	●	●			●	●	●
VALVE SEAT O-RINGS			●			●				●			●		●

Temperature Limits

NEOPRENE	0°F (-18°C) to +200°F (93°C)
BUNA-N	+10°F (-12°C) to +180°F (82°C)
NORDEL	-60°F (-51°C) to +280°F (138°C)
(FKM) FLUOROCARBON	-40°F (-40°C) to +350°F (176°C)
PTFE	+40°F (+4°C) to +220°F (105°C)
POLYURETHANE	+10°F (-12°C) to +170°F (77°C)
SANTOPRENE (TPE XL)	-20°F (-29°C) to +300°F (149°C)
PFA	-20°F (-29°C) to +300°F (149°C)
FDA HYTREL	-20°F (-29°C) to +220°F (104°C)

METALLIC PUMPS can operate past 212°F (100°C). However, if you are operating above these limits, consult the factory for assistance.

PLASTIC PUMPS can operate to the following temperature limits:

• ACETAL	32°F (0°C) to 220°F (104°C)
• POLYPROPYLENE	32°F (0°C) to 175°F (79°C)
• PVDF	10°F (-12°C) to 225°F (107°C)

NOTE: These are average temperatures. Chemicals and solvents can have an effect on temperature limit

Wetted Material Compatibility

Fluid Solutions	Numeric pH Level	Wetted Section Construction Metals
ALKALINE	14	STAINLESS STEEL
	13	
	12	
CAUSTIC	11	CAST IRON
	10	
BASIC	9	ALUMINUM
	8	
	7	
NEUTRAL	6	CAST IRON
	5	
	4	
ACID	3	STAINLESS STEEL
	2	
	1	
	0	

VERSA-MATIC® PRODUCT WARRANTY

Versa-Matic warrants to the original end-use purchaser that no product sold by Versa-Matic that bears a Versa-Matic brand shall fail under normal use and service due to a defect in material or workmanship within five years from the date of shipment from Versa-Matic's factory. Versa-Matic brands include ELIMA-MATIC®, TEF-MATIC®, THERMO-MATIC®, Ultra-Matic® and FUSION™.

If Versa-Matic determines that a product bearing a Versa-Matic brand has failed under normal use and service due to a defect in material or workmanship within the warranty period for such product, Versa-Matic will repair or replace such product at no charge to the original end-use purchaser. The determination to repair or replace shall be made by Versa-Matic in its sole discretion. The repaired or replacement product shall be shipped to the original end-user purchaser freight collect unless the original end-user purchaser makes other arrangements for shipment. The original end-user purchaser shall bear all risk of loss or damage during shipment. Repair or replacement does not extend the original warranty period for a product, and any warranty repair or replacement is warranted only for the balance of the original warranty period.

Statements and data relating to products on Versa-Matic's website and in promotional marketing and technical literature and materials are not intended to define the performance of any product under actual conditions or when used for specific applications, are not warranties, and should not be relied upon in determining the performance of products under actual conditions or the suitability of products for specific applications.

The above warranty and repair or replacement obligation does not apply to or include:

- Any product that is not sold by Versa-Matic as new
- Any accessory or other product that does not bear a Versa-Matic brand (In the case of such products, any warranty is limited to a pass through to the original end-use purchaser of any warranty received from the manufacturer to the extent such pass through is permitted by the manufacturer)
- Any product that fails other than during normal use and service or that fails outside the warranty period for such product
- Normal wear and tear
- Any product that Versa-Matic determines (a) was tampered with, disassembled, repaired, modified or altered without the prior written authorization of Versa-Matic (b) damaged during or after shipment (c) used to pump material that the product was not designed to pump or otherwise used for a purpose or under conditions that differ from those for which it was designed (d) not properly maintained or operated or otherwise misused or (e) subjected to abnormal use or service.
- Any party other than the original end-use purchaser
- Field repair, removal, reinstallation, labor, freight or other similar items

To be eligible for warranty repair or replacement, the original end-use purchaser must notify Versa-Matic of the product failure in writing within the warranty period for such product and, if requested by Versa-Matic, the product must be promptly returned for inspection, freight prepaid, to either Versa-Matic's factory at 800 North Main Street; Mansfield, OH 44901 or to a Versa-Matic authorized distributor. The original end-user purchaser must also promptly provide Versa-Matic or its authorized distributor with all such information as either of them may request concerning the maintenance, operation, use and failure of any product that is claimed to have failed due to a defect in material or workmanship. Return of a product to Versa-Matic's factory requires a Return Goods authorization (RGA) from Versa-Matic, and the RGA No. must be included with the returned product. The original end-user purchaser shall bear all risk of loss or damage during shipment.

THIS PRODUCT WARRANTY IS VERSA-MATIC'S SOLE AND EXCLUSIVE WARRANTY AND IS IN LIEU OF ALL OTHER WARRANTIES, EXPRESS OR IMPLIED, INCLUDING, BUT NOT LIMITED TO, ALL WARRANTIES OF MERCHANTABILITY AND FITNESS FOR A PARTICULAR PURPOSE, ALL OF WHICH OTHER WARRANTIES ARE EXPRESSLY EXCLUDED.

THE RIGHTS AND REMEDIES UNDER THIS PRODUCT WARRANTY ARE THE SOLE AND EXCLUSIVE RIGHTS AND REMEDIES AGAINST VERSA-MATIC WITH RESPECT TO ALL PRODUCTS. EXCEPT FOR THE SPECIFIC LIABILITIES AND OBLIGATIONS PROVIDED UNDER THIS PRODUCT WARRANTY, VERSA-MATIC SHALL HAVE NO LIABILITY OR OBLIGATION WITH RESPECT TO ANY PRODUCT.

UNDER NO CIRCUMSTANCES SHALL VERSA-MATIC HAVE ANY LIABILITY FOR ANY CLAIM, LOSS, DAMAGE, INJURY, LIABILITY, OBLIGATION, COST OR EXPENSE THAT DIRECTLY OR INDIRECTLY RELATES TO OR ARISES OUT OF THE USE OR FAILURE OF ANY PRODUCT OR ANY LIABILITY FOR INDIRECT, SPECIAL, PUNITIVE OR CONSEQUENTIAL DAMAGES, INCLUDING, BUT NOT LIMITED TO, LOSS OF SALES, LOSS OF PROFITS, LOSS OF MATERIAL BEING PUMPED, DOWN TIME, LOSS OF PRODUCTION, LOSS OF CONTRACTS, OR DAMAGE TO REPUTATION OR GOOD WILL, WHETHER OR NOT VERSA-MATIC WAS AWARE OF OR ADVISED OF THE POSSIBILITY OF SUCH DAMAGES.

IN ANY EVENT, VERSA-MATIC'S LIABILITY IN CONNECTION WITH ANY INDIVIDUAL PRODUCT SHALL BE LIMITED TO THE ORIGINAL PRICE PAID TO VERSA-MATIC FOR SUCH PRODUCT.

No Versa-Matic authorized distributor or other person is authorized to modify this Product Warranty or impose any liability or obligation on Versa-Matic other than as expressly provided herein.

DECLARATION OF CONFORMITY

DECLARATION DE CONFORMITE • DECLARACION DE CONFORMIDAD • ERKLÄRUNG BEZÜGLICH EINHALTUNG DER VORSCHRIFTEN
DICHIARAZIONE DI CONFORMITÀ • CONFORMITEITSVERKLARING • DEKLARATION OM ÖVERENSSTÄMMELSE
EF-OVERENSSTÄMMELSESERKLÆRING • VAATIMUSTENMUKAISUUSVAKUUTUS • SAMSVARERKLÄRING • DECLARAÇÃO DE CONFORMIDADE

MANUFACTURED BY:

FABRIQUE PAR:
FABRICADA POR:
HERGESTELLT VON:
FABBRICATO DA:
VERVAARDIGD DOOR:
TILLVERKAD AV:
FABRIKANT:
VALMISTAJA:
PRODUSENT:
FABRICANTE:

VERSA-MATIC®
IDEX AODD, Inc.
A Unit of IDEX Corporation
800 North Main Street, P.O. Box 1568
Mansfield, OH 44901-1568 • USA
Phone: (419) 526-7296
Fax: (419) 526-7289

VERSA-MATIC®

PUMP MODEL SERIES: E1 SERIES, E2 SERIES, E3 SERIES, E4 SERIES, E5 SERIES, E7 SERIES, E8 SERIES AND U2 SERIES:

This product complies with the following European Community Directives:

98 / 37 / EC

Ce produit est conforme aux directives de la Communauté européenne suivantes:
Este producto cumple con las siguientes Directrices de la Comunidad Europea:
Dieses produkt erfüllt die folgenden Vorschriften der Europäischen Gemeinschaft:
Questo prodotto è conforme alle seguenti direttive CEE:
Dir produkt voldoet aan de volgende EG-richtlijnen:
Denna produkt överensstämmer med följande EU direktiv:
Versa-Matic, Inc., erklærer herved som fabrikant, at ovennævnte produkt er i overensstemmelse med bestemmelserne i Direktive:
Tämä tuote täyttää seuraavien EC Direktiivien vaatimukset:
Dette produkt oppfyller kravene til følgende EC Direktiver:
Este produto está de acordo com as seguintes Directivas comunitárias:

This product has used the following harmonized standards to verify conformance:

EN 809

Ce matériel est fabriqué selon les normes harmonisées suivantes, afin d' en garantir la conformité:
Este producto cumple con las siguientes directrices de la comunidad europea:
Dieses produkt ist nach folgenden harmonisierten standards gefertigt worden, die übereinstimmung wird bestätigt:
Questo prodotto ha utilizzato i seguenti standards per verificare la conformità:
De volgende geharmoniseerde normen werden gehanteerd om de conformiteit van dit produkt te garanderen:
För denna produkt har följande harmoniserande standarder använts för att bekräfta överensstämmelse:
Harmoniserede standarder, der er benyttet:
Tässä tuotteessa on sovellettu seuraavia yhdenmukaistettuja standardeja:
Dette produkt er produsert i overensstemmelse med følgende harmoniserte standarder:
Este produto utilizou os seguintes padrões harmonizados para verificar conformidade:

AUTHORIZED/APPROVED BY:

Approuve par:
Aprobado por:
Genehmigt von:
approvato da:
Goedgekeurd door:
Underskrift:
Valtuutettuna:
Bemyndiget av:
Autorizado Por:

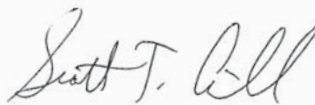

Scott Aiello
Vice President of
Commercial Operations



Erik Dillen,
Engineering Manager

DATE: March 11, 2008

FECHA:
DATUM:
DATA:
DATO:
PÄIVÄYS:



