

## 2" Ultra-Matic™ Clamped Metallic Pumps

# U2

- Aluminum
- Cast Iron
- Hastelloy C
- Stainless Steel

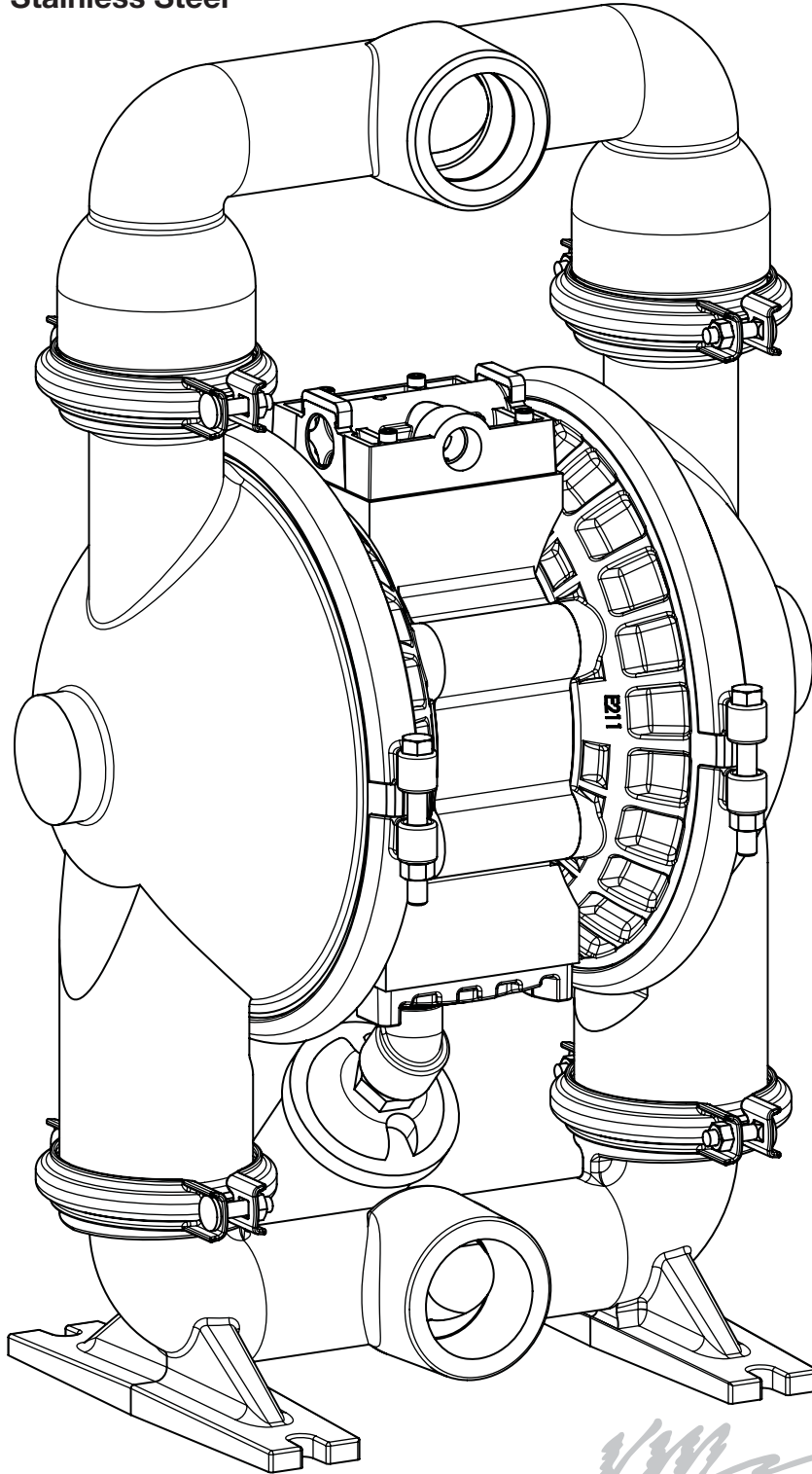

  
**VERSA-MATIC®**

# WARNINGS, CAUTIONS & NOTICES

Please read all cautions, warnings and notes completely before installation and start-up. It is the responsibility of the purchaser to retain

this manual for reference. Failure to comply with the recommendations stated in this manual may damage the pump and void the factory warranty.

## WARNINGS



**To prevent static sparking the pump, piping, valves, and containers must be grounded.** Fire or explosion can occur when handling flammable fluids and whenever discharge of static electricity is a hazard.



**Pump exhaust may contain contaminants that can cause serious injury. Take precautions to pipe exhaust away from work area if pumping chemicals, hazardous or flammable materials.**

## CAUTIONS



**You must check the tightness of all hardware prior to installation.**



**Do not exceed the maximum inlet air pressure as stated on the pump model tag.**



**Maximum temperature limits are based on mechanical stress only. Certain chemicals will significantly reduce maximum safe operating temperatures.** For chemical compatibility and temperature limits please refer to the Chemical Resistance Guide.



**Disconnect the compressed air line to the pump and allow all air pressure to bleed from pump prior to performing any maintenance on the pump. Disconnect all intake, discharge and air lines. Drain the pump and dispose of fluid into a suitable container.**



**Check temperature limits for all wetted components when choosing pump materials.** Temperature limits may vary depending on the material.



**All operators of the equipment should be properly trained to ensure safe working practices.**



**The process fluid and cleaning fluids must be chemically compatible with all wetted pump components.** Please refer to the Chemical Resistance Guide for additional information.



**Never allow the piping system to be supported by the pump manifolds or valve housing.** These components are not designed to support structural weight and pump failure may result..



**Thoroughly flush pump before installing into process lines.** FDA and sanitary approved pumps should be cleaned or sanitized before use.



Noise levels can exceed 85 dBA. **Always wear ear and eye protection when operating or repairing pumps.**

## NOTICES



**Blow out air line for at least 15 seconds before attaching to pump** to make sure that all debris is removed. Use an in-line air filter.



**Compressed air should not be applied to the exhaust port.** If this happens the pump will not function.



Clamp style pumps fitted with PTFE or XLTPPE come standard from the factory with expanded PTFE liquid chamber gaskets. **PTFE gaskets cannot be reused.**



**Before disassembly of clamp band pumps, mark a line from each liquid chamber to its corresponding air chamber.** This will ensure proper alignment when reassembling.



**Tighten both outer pistons at the same time to ensure a tight fit when installing PTFE diaphragms.** See torque settings for additional details.



**The pump does not require continuous lubrication.**

# VERSA-MATIC® MODEL IDENTIFICATION CODES

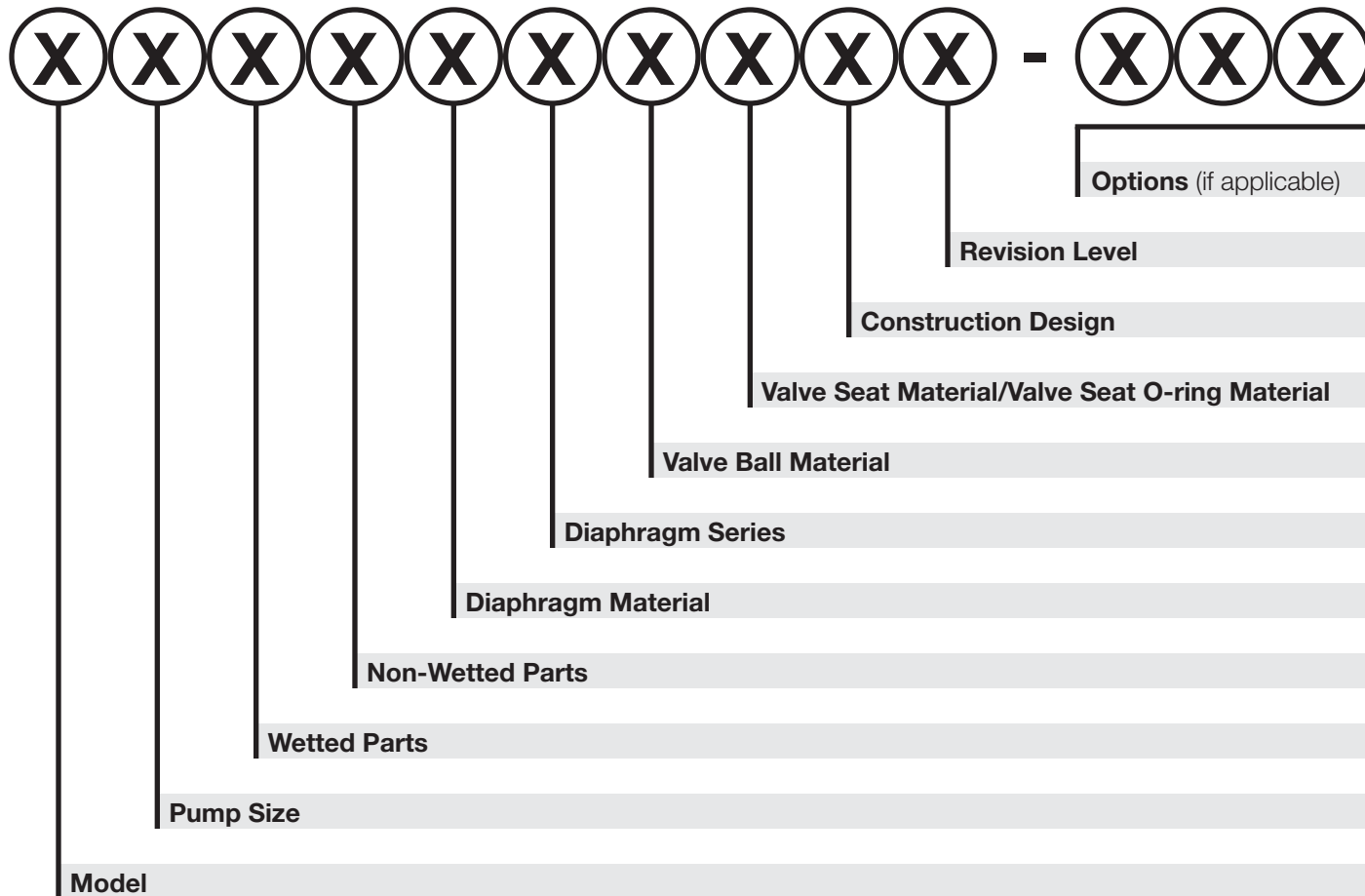

## Model

**E** Elima-Matic  
**U** Ultra-Matic  
**V** V-Series

## Pump Size

**6** 1/4"  
**8** 3/8"  
**5** 1/2"  
**7** 3/4"  
**1** 1"  
**4** 1-1/4" or 1-1/2"  
**2** 2"  
**3** 3"

## Wetted Parts

**A** Aluminum  
**C** Cast Iron  
**S** Stainless Steel  
**H** Hastelloy C  
**P** Polypropylene  
**K** PVDF  
**G** Groundable Acetal  
**B** Aluminum (screen mount)

## Non-Wetted Parts

**A** Aluminum  
**S** Stainless Steel  
**P** Polypropylene  
**G** Groundable Acetal  
**Z** PTFE-coated Aluminum  
**J** Nickel-plated Aluminum  
**C** Cast Iron  
**Q** Epoxy-Coated Aluminum

## Diaphragm Material

**1** Neoprene  
**2** Buna-N  
**3** (FKM) Fluorocarbon  
**4** Nordel  
**5** PTFE  
**6** XL  
**7** Hytrel  
**9** Geolast

## Diaphragm Series

**R** Rugged  
**D** Dome  
**X** Thermo-Matic  
**T** Tef-Matic (2-piece)  
**B** Versa-Tuff (1-piece)  
**F** FUSION (one-piece integrated plate)

## Valve Ball Material

**1** Neoprene  
**2** Buna-N  
**3** (FKM) Fluorocarbon  
**4** Nordel  
**5** PTFE  
**6** XL  
**7** Hytrel  
**8** Polyurethane  
**9** Geolast  
**A** Acetal  
**S** Stainless Steel

## Valve Seat/Valve Seat O-ring Material

**1** Neoprene  
**2** Buna-N  
**3** (FKM) Fluorocarbon  
**4** Nordel  
**5** PTFE  
**6** XL  
**7** Hytrel  
**8** Polyurethane  
**9** Geolast  
**A** Aluminum w/ PTFE O-rings  
**S** Stainless Steel w/ PTFE O-rings  
**C** Carbon Steel w/ PTFE O-rings  
**H** Hastelloy C w/ PTFE O-rings  
**T** PTFE Encapsulated Silicone O-rings

## Construction Design

**9** Bolted  
**0** Clamped

# U2C SPECIFICATIONS & PERFORMANCE

## Specifications

|                            | English             | Metric    |
|----------------------------|---------------------|-----------|
| <b>Flow rate</b>           |                     |           |
| adjustable to              | 0-182 gpm           | 0-689 lpm |
| <b>Port size</b>           |                     |           |
| Inlet and Outlet           | 2" Female NPT (BSP) |           |
| <b>Air inlet</b>           | 0.50" Female NPT    |           |
| <b>Air exhaust</b>         | 0.75" Female NPT    |           |
| <b>Suction lift*</b> (dry) |                     |           |
| Rubber                     | 20'                 | 6.10 m    |
| PTFE                       | 10'                 | 3.05 m    |
| <b>Max. particle size</b>  |                     |           |
| Diameter                   | 0.25"               | 6 mm      |
| <b>Shipping weight</b>     |                     |           |
| Aluminum                   | 69 lbs              | 31 kg     |
| Cast Iron                  | 114 lbs             | 52 kg     |
| Hastelloy                  | 124 lbs             | 56 kg     |
| Stainless Steel            | 114 lbs             | 52 kg     |



## Performance

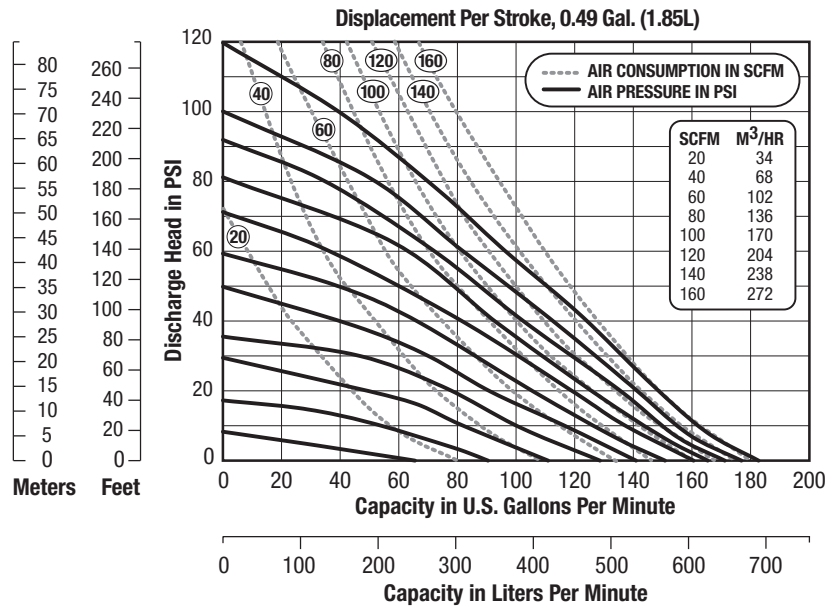

**NOTE:** For U2 pumps fitted with PTFE diaphragms, reduce water discharge figures by 20%. Suction lift is reduced to 10' (3.05m) dry and 20' (6.10m) wet.

**CAUTION:** Do not exceed 125 psig (8.5 bars) air supply or liquid pressure.

## Dimensions

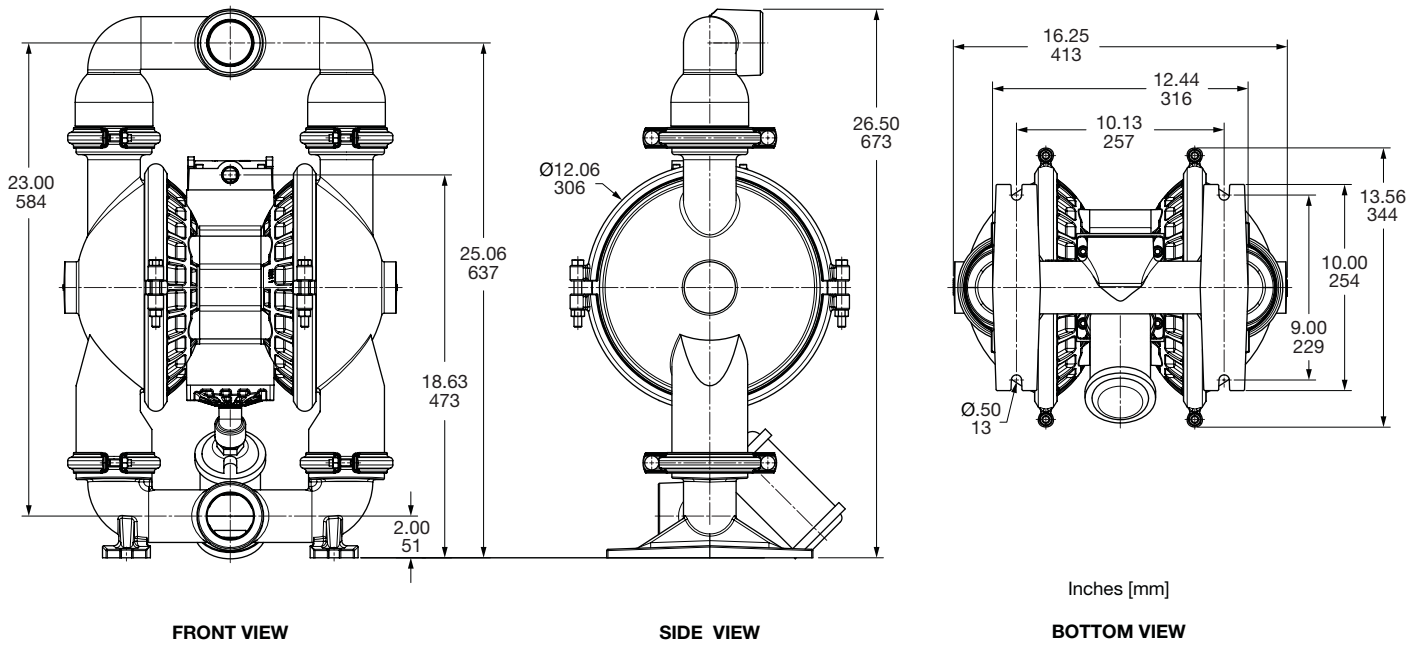

Consult factory for certified drawings.

# INSTALLATION, OPERATION & MAINTENANCE

## Installation

The pump should be mounted in a vertical position. In permanent installations, the pump should be attached to plant piping using a flexible coupling on both the intake and discharge connections to reduce vibration to the pump and piping. To further reduce vibration, a surge suppressor next to the pump may be used.

Suction pipe size should be at least the same diameter as the inlet connection size, even larger if highly viscous fluid is to be pumped. If suction hose is used, it must be of a non-collapsible reinforced type. Discharge piping should be of at least the same diameter as the discharge connection.

It is critical, especially on the suction side of the pump, that all fittings and connections are air tight or pumping efficiency will be reduced and priming will be difficult.

Make certain the air supply line and connections and compressor are capable of supplying the required pressure and volume of air to operate the pump at the desired flow rate. The quality of the compressed air source should be considered. Air that is contaminated with moisture and dirt may result in erratic pump performance and increased maintenance cost as well as frequent process "down time" when the pump fails to operate properly.

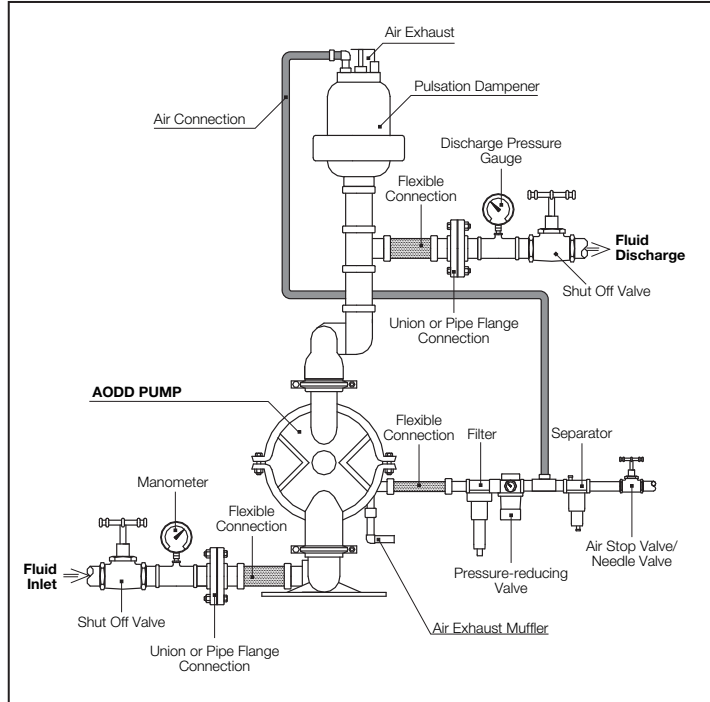

## Pump Operation

The pump is powered by compressed air. Compressed air is directed to the pump air chamber by the main air valve. The compressed air is

separated from the fluid by a membrane called a diaphragm. The diaphragm in turn applies pressure on the fluid and forces it out of the pump discharge. While this is occurring, the opposite air chamber is de-pressurized and exhausted to atmosphere and fluid is drawn into the pump suction. The cycle again repeats, thus creating a constant reciprocating action which maintains flow through the pump. The flow is always in through the bottom suction connection

and out through the top discharge connection. Since the air pressure acts directly on the diaphragms, the pressure applied to the fluid roughly approximates the air supply pressure supplied to the main air valve.

## Recommended Piping Connections

| Pump Size | Minimum Air Line Size | Minimum Suction Line Size |
|-----------|-----------------------|---------------------------|
| 1/4"      | 1/4"                  | 1/4"                      |
| 3/8"      | 1/4"                  | 3/8"                      |
| 1/2"      | 1/2"                  | 1/2"                      |
| 1"        | 1/2"                  | 1"                        |
| 1-1/2"    | 1/2"                  | 1-1/2"                    |
| 2"        | 1/2"                  | 2"                        |
| 3"        | 3/4"                  | 3"                        |

# TROUBLESHOOTING

| Symptom                                       | Potential Cause(s)   | Recommendation(s)   |
|---|--|---|
| <b>Pump cycles once</b>                       | <ol style="list-style-type: none"> <li>1 Incorrect pilot o-ring placement</li> <li>2 Inner diaphragm plate installed backwards</li> <li>3 Deadhead (system pressure meets or exceeds air supply pressure)</li> <li>4 Air valve or center block gaskets installed incorrectly</li> </ol>  | <ol style="list-style-type: none"> <li>1 Reinstall pilot o-rings in correct positions</li> <li>2 Reinstall inner diaphragm plate correctly</li> <li>3 Check system for pressure ratio to pump</li> <li>4 Install gaskets with holes properly aligned</li> </ol>   |
| <b>Pump will not operate</b>                  | <ol style="list-style-type: none"> <li>1 Pump is over lubricated</li> <li>2 Lack of air (line size, PSI, CFM)</li> <li>3 Worn o-rings</li> <li>4 Wrong type of lubrication (attack on o-rings)</li> <li>5 Debris in air valve</li> <li>6 Clogged manifolds</li> <li>7 Incorrect o-ring placement</li> <li>8 Deadhead (system pressure meets or exceeds air supply pressure)</li> </ol>             | <ol style="list-style-type: none"> <li>1 Set lubricator on lowest possible setting or remove <ul style="list-style-type: none"> <li>• Elima-Matic is designed for lube free operation</li> </ul> </li> <li>2 Check the air line size and length, compressor capacity (HP vs. cfm required)</li> <li>3 Replace o-rings</li> <li>4 Check compatibility of o-rings with lubrication</li> <li>5 Clean air valve/filter</li> <li>6 Clean suction or discharge manifolds/piping</li> <li>7 Reinstall o-rings in correct position</li> <li>8 Increase air supply pressure</li> </ol>   |
| <b>Pump cycles and will not prime or flow</b> | <ol style="list-style-type: none"> <li>1 Cavitation on suction side</li> <li>2 Valve ball(s) not seating properly or sticking</li> <li>3 Valve ball(s) missing (pushed into chamber)</li> <li>4 Valve ball(s)/seat(s) damaged or attacked by product</li> <li>5 Clogged suction line</li> </ol>  | <ol style="list-style-type: none"> <li>1 Check suction condition (move pump closer to product)</li> <li>2 Clean out around valve ball cage and valve seat area <ul style="list-style-type: none"> <li>• Replace valve ball or valve seat if damaged</li> <li>• Use heavier valve ball material</li> </ul> </li> <li>3 Worn valve ball or valve seat <ul style="list-style-type: none"> <li>• Worn fingers in valve ball cage (replace part)</li> </ul> </li> <li>4 Check Chemical Resistance Guide for compatibility</li> <li>5 Clean suction manifold and/or piping</li> </ol>   |
| <b>Pump running sluggish/stalling</b>         | <ol style="list-style-type: none"> <li>1 Over lubrication</li> <li>2 Icing</li> <li>3 Clogged manifolds</li> <li>4 Deadhead (system pressure meets or exceeds air supply pressure)</li> <li>5 Cavitation on suction side</li> <li>6 Lack of air (line size, PSI, CFM)</li> </ol>   | <ol style="list-style-type: none"> <li>1 Set lubricator on lowest possible setting or remove <ul style="list-style-type: none"> <li>• Elima-Matic is designed for lube free operation</li> </ul> </li> <li>2 Clean or replace exhaust muffler</li> <li>3 Clean manifolds to allow proper air flow</li> <li>4 Check system to locate deadhead (equilibrium) <ul style="list-style-type: none"> <li>• Increase air supply pressure</li> </ul> </li> <li>5 Check suction (move pump closer to product)</li> <li>6 Check the air line size, length, compressor capacity</li> </ol>  |
| <b>Product leaking through exhaust</b>        | <ol style="list-style-type: none"> <li>1 Diaphragm failure, or diaphragm plates loose</li> <li>2 Diaphragm stretched around center hole or bolt holes</li> <li>3 Excessive air supply pressure</li> </ol>  | <ol style="list-style-type: none"> <li>1 Replace diaphragms, check for damage and ensure diaphragm plates are tight</li> <li>2 Check for excessive inlet pressure or air pressure <ul style="list-style-type: none"> <li>• Tighten bolts to recommended torque</li> </ul> </li> <li>3 Check Operating Manual for recommendations</li> </ol>   |
| <b>Premature diaphragm failure</b>            | <ol style="list-style-type: none"> <li>1 Cavitation</li> <li>2 Excessive flooded suction pressure</li> <li>3 Misapplication (chemical/physical incompatibility)</li> <li>4 Wrong type of lubrication (attack on air side)</li> <li>5 Incorrect diaphragm plates or plates on backwards</li> <li>6 Incorrect shaft with corresponding elastomer</li> <li>7 Start up at full air pressure</li> </ol> | <ol style="list-style-type: none"> <li>1 Enlarge pipe diameter on suction side of pump</li> <li>1,2 Move pump closer to product <ul style="list-style-type: none"> <li>• Raise pump/place pump on top of tank to reduce inlet pressure</li> </ul> </li> <li>2 Add accumulation tank or pulsation dampener as close to the pump as possible</li> <li>3,4 Consult Chemical Resistance Chart for compatibility with products, cleaners, temperature limitations and lubrication</li> <li>5,6 Check Operating Manual to check for correct part and installation</li> <li>7 Start up pump slowly (manually or with Smart Start)</li> </ol> |
| <b>Breaking and bending shafts</b>            | <ol style="list-style-type: none"> <li>1 Build up of solids in water chamber</li> <li>2 Loose diaphragm plates</li> </ol>  | <ol style="list-style-type: none"> <li>1 Flush pump, start pump slow</li> <li>2 Tighten diaphragm plates when replacing diaphragms</li> </ol>   |

# U2C PARTS LIST

## AIR VALVE ASSEMBLY

| Item | Description                                 | Qty | Standard: Polypropylene      |
|------|---|-----|------------------------------|
|      | Air Valve Assembly<br>(Includes items 1-10) | 1   | E200                         |
| 1    | Valve Body                                  | 1   | E200A                        |
| 2    | Valve Spool Assembly                        | 1   | E200B ASY (Includes U-Cups)  |
| 3    | Valve Spool U-Cup                           | 2   | P98-104A                     |
| 4    | End Cap Assembly                            | 2   | E500D ASY (Includes O-Rings) |
| 5    | End Cap Staple                              | 2   | E500F                        |
| 6    | Staple Retainer                             | 2   | E200L                        |
| 7    | Air Diverter                                | 1   | E200G                        |
| 8    | Valve Insert                                | 1   | E200H                        |
| 9    | Valve Gasket                                | 1   | E200J                        |
| 10   | Valve Cap Screw                             | 4   | P24-209                      |

## AIR END ASSEMBLY

| Item | Description                        | Qty | Standard: Polypropylene / Aluminum | Option1: Polypropylene / Stainles |
|------|------------------------------------|-----|------------------------------------|-----------------------------------|
| 15   | Center Block                       | 1   | E210                               | E210                              |
| 16   | Air Chamber Gasket                 | 2   | E212                               | E212                              |
| 17   | Air Chamber                        | 2   | E211                               | SE211                             |
| 18   | Air Chamber Bolt                   | 12  | V302G                              | V181F                             |
| 19   | Air Chamber Nut                    | 2   | V354C                              | SV354C                            |
| 20   | Air Chamber Washer                 | 12  | V302GA                             | SV302GA                           |
| 21   | Bushing                            | 2   | E201MB                             | E201MB                            |
| 22   | Pilot Shaft                        | 1   | E203A                              | E203A                             |
| 23   | Pilot Shaft Spacer                 | 5   | P24-106P                           | P24-106P                          |
| 24   | Pilot Shaft O-Ring                 | 6   | P24-107                            | P24-107                           |
| 25   | Stop Nut                           | 2   | P24-108                            | P24-108                           |
| 26   | Shaft Retainer – Left              | 1   | E201B-L ASY (Includes O-Rings)     | E201B-L ASY (Includes O-Rings)    |
| 27   | Shaft Retainer – Right (not shown) | 1   | E201B-R ASY (Includes O-Rings)     | E201B-R ASY (Includes O-Rings)    |
| 28   | Shaft Retainer O-Ring              | 2   | E201B-5                            | E201B-5                           |
| 29   | Shaft Retainer Screw               | 8   | 10-050                             | 10-050                            |
| 30   | Exhaust Valve                      | 2   | E202 ASY                           | E202 ASY                          |
| 31   | Exhaust Sleeve O-Ring              | 2   | E201M-1                            | E201M-1                           |
| 32   | Retainer Plate Seal                | 2   | E201B-3                            | E201B-3                           |
| 33   | Muffler Plate                      | 1   | E201H                              | E201H                             |
| 34   | Muffler Plate Gasket               | 1   | E200J-1                            | E200J-1                           |
| 35   | Muffler Plate Cap Screw            | 4   | E201G                              | E201G                             |
| 36   | Muffler Elbow                      | 1   | PE201N                             | PE201N                            |
| 37   | Muffler                            | 1   | V20AEM                             | V20AEM                            |
| 38   | Air Chamber O-Ring                 | 2   | P24-107                            | P24-107                           |

## DIAPHRAGM ASSEMBLY

| Item | Description           | Qty | Rugged   | Dome   | Teflon Bonded             | Teflon 2-Piece            |
|------|-----------------------|-----|--|--|---------------------------|---------------------------|
| 40   | Main Shaft            | 1   | P24-103  | P24-103  | P24-102                   | P24-102                   |
| 41   | Diaphragm Shaft Stud  | 2   | N/A  | N/A  | V221F                     | V221F                     |
| 42   | Inner Diaphragm Plate | 2   | V221B  | V226B  | V221TI                    | V221TI                    |
| 43   | Outer Diaphragm Plate | 2   | VB221 SVB221<br>WVB221 HVB221                        | VB226 SVB226<br>HVB226                               | V221TO SV221TO<br>HV221TO | V221TO SV221TO<br>HV221TO |
| 44   | Diaphragm O-Ring      | 2   | V221D  | N/A  | N/A                       | N/A                       |
| 45   | Diaphragm             | 2   | V224BN V224N<br>V224ND V224VT<br>V224TPEXL V224TPEFG | V225BN V225N<br>V225ND V225VT<br>V225TPEXL V225TPEFG | V224TX                    | V224TF                    |
| 46   | Back-up Diaphragm     | 2   | N/A  | N/A  | N/A                       | V224TFB                   |

## WET END ASSEMBLY

| Item | Description                   | Qty | Standard:<br>Aluminum  | Option1:<br>Stainless Steel | Option 2:<br>Hastelloy | Option 3:<br>Cast Iron |
|------|-------------------------------|-----|--|-----------------------------|------------------------|------------------------|
| 50   | Water Chamber                 | 2   | V235   | SV235                       | HV235                  | WV235                  |
| 51   | Large Clamp Bolt              | 4   | V230C  | SV230C                      | SV230C                 | V230C                  |
| 52   | Large Clamp Nut               | 4   | V230D  | SV230D                      | SV230D                 | V230D                  |
| 53   | Large Clamp Assembly          | 4   | V230   | SV230                       | SV230                  | V230                   |
| 54   | Valve Seat                    | 4   | V240BN V240N V240ND V240TPEFG V240TF V240VT<br>V240TPEXL V240A SV240 HV240 WV240 |                             |                        |                        |
| 55   | Valve Seat O-Ring (not shown) | 4   | V240T (Use with V240A, SV240, HV240, WV240 only)                                 |                             |                        |                        |
| 56   | Valve Ball                    | 4   | V241BN V241N V241ND V241P V241TPEXL V240TPEFG V241VT V240SS                      |                             |                        |                        |
| 57   | Discharge Manifold            | 1   | V236*  | SV236*                      | HV236*                 | WV236*                 |
| 58   | Inlet Manifold                | 1   | V237F*   | SV237F*                     | HV237F*                | WV237F*                |
| 59   | Small Clamp Bolt              | 8   | V239B  | SV239B                      | V239B                  | SV239B                 |
| 60   | Small Clamp Nut               | 8   | V239C  | SV239C                      | V239C                  | SV239C                 |
| 61   | Small Clamp Assembly          | 8   | V239   | SV239                       | V239                   | SV239                  |

## OPTIONAL SCREEN BASE ASSEMBLY

| Item | Description                | Qty | Standard: Aluminum |
|------|----------------------------|-----|--------------------|
| 65   | Screen Base                | 1   | V238               |
| 66   | Screen Base Inlet Manifold | 1   | V237               |
| 67   | Inlet Cover                | 1   | V242               |
| 68   | Screen Base Bolts          | 3   | V238A              |

\* Add "BSP" for BSP threads.

# U2C EXPLODED VIEW

## Torque Settings

|                           |                     |
|---------------------------|---------------------|
| Small Clamp Bolts         | 50 in-lbs (5.6 N-m) |
| Large Clamp Bolts         | 20ft-lbs (27 N-m)   |
| Diaphragm Plates — Rubber | 65 ft-lbs (88 N-m)  |
| Diaphragm Plates — PTFE   | 65 ft-lbs (88 N-m)  |
| Air Valve Cap Screws      | 25 in-lbs (2.8 N-m) |
| Muffler Plate Cap Screws  | 30 in-lbs (3.4 N-m) |
| Air Chamber Bolts         | 20 ft-lbs (27 N-m)  |

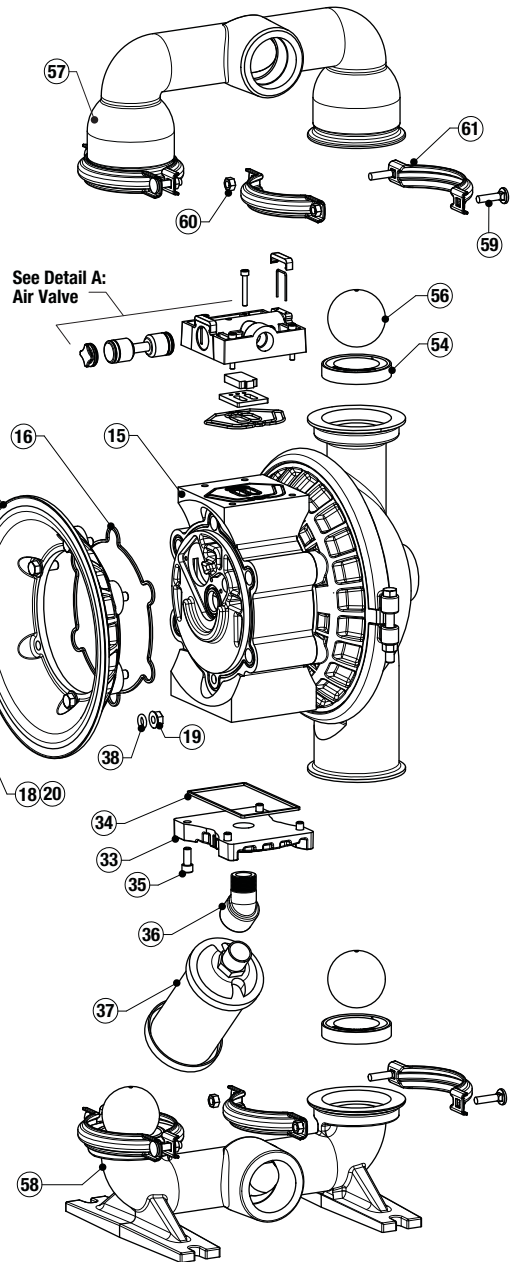
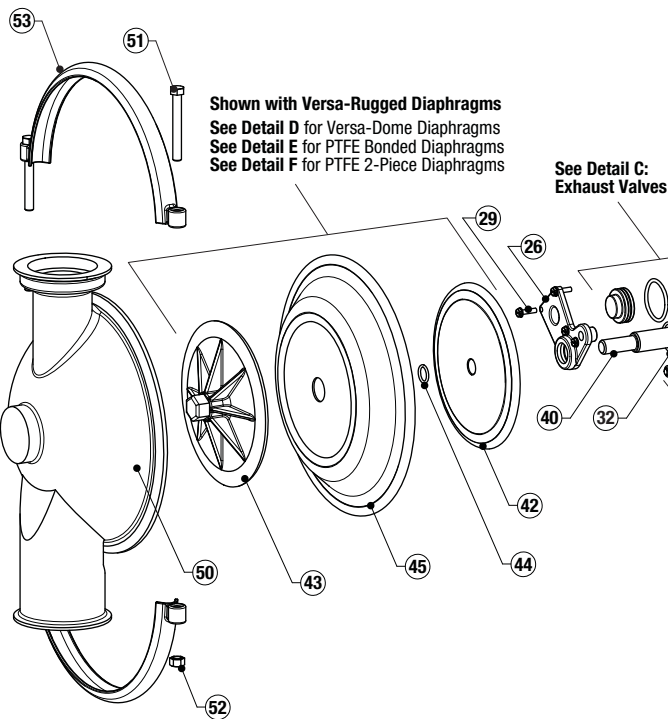

## Optional Screen Base

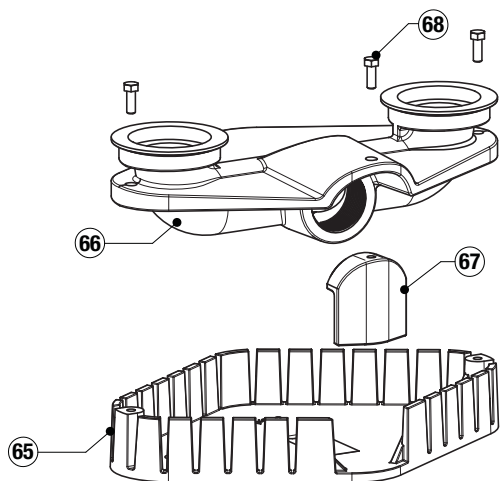

# U2C DETAIL VIEWS

Detail A

Air Valve Assembly

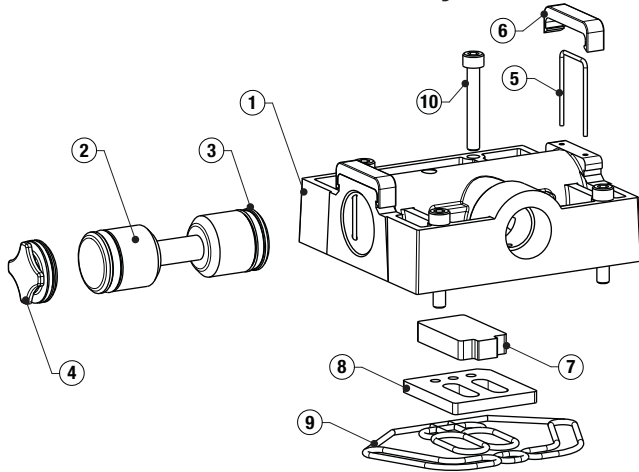

Detail B

Pilot Shaft Assembly

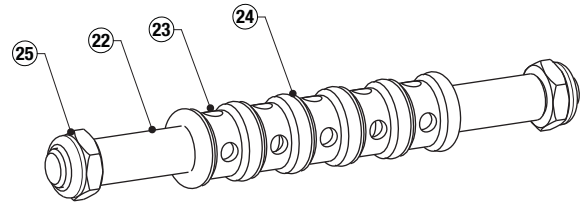

Detail C

Exhaust Valve Assembly

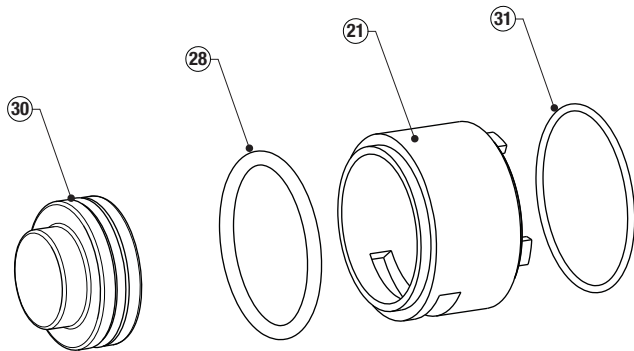

Detail D

Versa-Dome Diaphragms

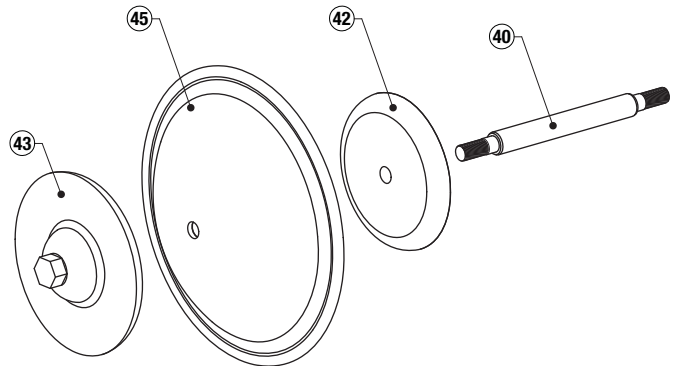

Detail E

PTFE Bonded Diaphragms

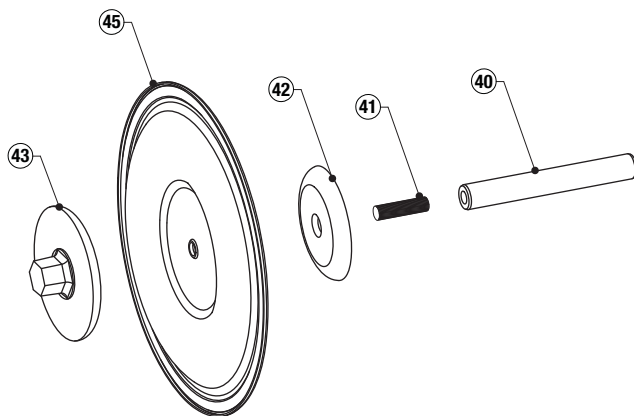

Detail F

PTFE 2-Piece Diaphragms

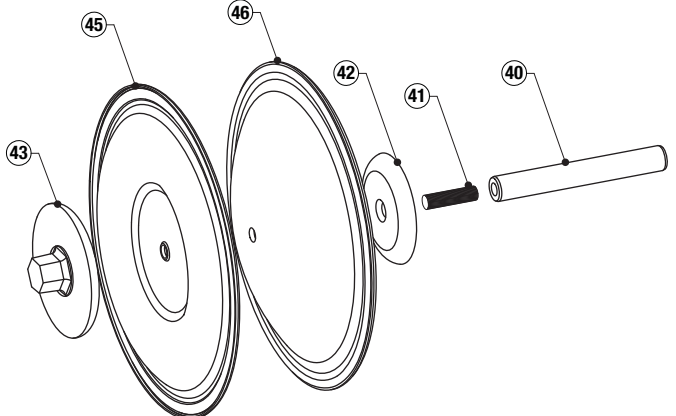

# MATERIALS, TEMPERATURE LIMITS & COMPATIBILITY

## Materials of Construction — Pumps

| MODEL                | Acetal® | Aluminum | Cast Iron | Hastelloy C | Polypropylene | PVDF | Stainless Steel |
|----------------------|---------|----------|-----------|-------------|---------------|------|-----------------|
| E6 (1/4")            | ■       |          |           |             | ■             | ■    |                 |
| E8 (3/8")            |         |          |           |             | ●             | ●    |                 |
| E5 (1/2")            | ●       | ●        |           | ●           | ●▲            | ●▲   | ●               |
| E7 (3/4")            |         | ●        |           |             |               |      |                 |
| E1 (1")              |         | ●        |           | ●           | ●▲            | ●▲   | ●               |
| E4 (1-1/4" – 1-1/2") |         | ■        | ■         | ●■          | ●             | ●    | ●■              |
| E2 (2")              |         | ●■       | ●■        | ●■          | ●             | ●    | ●■▲▼            |
| E2-FV (2")           |         | ■        |           |             |               |      |                 |
| E3 (3")              |         | ●■       | ■         | ●■          | ●             | ●    | ●■              |

● Bolted Construction   ■ Clamped Construction   ▲ Split Manifold Model Available   ▼ High Pressure Model Available

## Diaphragms, Valve Balls, Valve Seats & Valve Seat O-rings

|                           | Aluminum | Buna-N | PVDF | Neoprene | EPDM | Polypropylene | Polyurethane | 316 Stainless Steel | PTFE       |             |         | Encapsulated Silicone | Thermoplastics      |             | (FKM) Fluorocarbon |
|---------------------------|----------|--------|------|----------|------|---------------|--------------|---------------------|------------|-------------|---------|-----------------------|---------------------|-------------|--------------------|
|                           |          |        |      |          |      |               |              |                     | Tef-Matic™ | Versa-Tuff™ | FUSION™ |                       | Santoprene (TPE XL) | FDA Hytrel® |                    |
| <b>ELASTOMERS</b>         |          |        |      |          |      |               |              |                     |            |             |         |                       |                     |             |                    |
| <b>DIAPHRAGMS</b>         |          |        | ●    |          | ●    | ●             |              |                     |            | ●           | ●       |                       | ●                   | ●           | ●                  |
| <b>VALVE BALLS</b>        |          |        | ●    |          | ●    | ●             |              | ●                   | ●          | ●           |         |                       | ●                   | ●           | ●                  |
| <b>VALVE SEATS</b>        |          | ●      | ●    | ●        | ●    | ●             | ●            | ●                   | ●          | ●           |         |                       | ●                   | ●           | ●                  |
| <b>VALVE SEAT O-RINGS</b> |          |        | ●    |          |      | ●             |              |                     |            | ●           |         |                       | ●                   |             | ●                  |

## Temperature Limits

|                            |                                 |
|----------------------------|---------------------------------|
| <b>NEOPRENE</b>            | 0°F (-18°C) to +200°F (93°C)    |
| <b>BUNA-N</b>              | +10°F (-12°C) to +180°F (82°C)  |
| <b>NORDEL</b>              | -60°F (-51°C) to +280°F (138°C) |
| <b>(FKM) FLUOROCARBON</b>  | -40°F (-40°C) to +350°F (176°C) |
| <b>PTFE</b>                | +40°F (+4°C) to +220°F (105°C)  |
| <b>POLYURETHANE</b>        | +10°F (-12°C) to +170°F (77°C)  |
| <b>SANTOPRENE (TPE XL)</b> | -20°F (-29°C) to +300°F (149°C) |
| <b>PFA</b>                 | -20°F (-29°C) to +300°F (149°C) |
| <b>FDA HYTREL</b>          | -20°F (-29°C) to +220°F (104°C) |

**METALLIC PUMPS** can operate past 212°F (100°C). However, if you are operating above these limits, consult the factory for assistance.

**PLASTIC PUMPS** can operate to the following temperature limits:

|                 |                               |
|-----------------|-------------------------------|
| • ACETAL        | 32°F (0°C) to 220°F (104°C)   |
| • POLYPROPYLENE | 32°F (0°C) to 175°F (79°C)    |
| • PVDF          | 10°F (-12°C) to 225°F (107°C) |

**NOTE:** These are average temperatures. Chemicals and solvents can have an effect on temperature limit

## Wetted Material Compatibility

| Fluid Solutions | Numeric pH Level | Wetted Section Construction Metals |
|-----------------|------------------|------------------------------------|
| <b>ALKALINE</b> | 14               | <b>STAINLESS STEEL</b>             |
|                 | 13               |                                    |
|                 | 12               |                                    |
| <b>CAUSTIC</b>  | 11               | <b>CAST IRON</b>                   |
|                 | 10               |                                    |
| <b>BASIC</b>    | 9                | <b>ALUMINUM</b>                    |
|                 | 8                |                                    |
|                 | 7                |                                    |
| <b>NEUTRAL</b>  | 6                | <b>CAST IRON</b>                   |
|                 | 5                |                                    |
| <b>ACID</b>     | 4                | <b>STAINLESS STEEL</b>             |
|                 | 3                |                                    |
|                 | 2                |                                    |
|                 | 1                |                                    |
|                 | 0                |                                    |

# VERSA-MATIC® PRODUCT WARRANTY

Versa-Matic warrants to the original end-use purchaser that no product sold by Versa-Matic that bears a Versa-Matic brand shall fail under normal use and service due to a defect in material or workmanship within five years from the date of shipment from Versa-Matic's factory. Versa-Matic brands include ELIMA-MATIC®, TEF-MATIC®, THERMO-MATIC®, Ultra-Matic® and FUSION™.

If Versa-Matic determines that a product bearing a Versa-Matic brand has failed under normal use and service due to a defect in material or workmanship within the warranty period for such product, Versa-Matic will repair or replace such product at no charge to the original end-use purchaser. The determination to repair or replace shall be made by Versa-Matic in its sole discretion. The repaired or replacement product shall be shipped to the original end-user purchaser freight collect unless the original end-user purchaser makes other arrangements for shipment. The original end-user purchaser shall bear all risk of loss or damage during shipment. Repair or replacement does not extend the original warranty period for a product, and any warranty repair or replacement is warranted only for the balance of the original warranty period.

Statements and data relating to products on Versa-Matic's website and in promotional marketing and technical literature and materials are not intended to define the performance of any product under actual conditions or when used for specific applications, are not warranties, and should not be relied upon in determining the performance of products under actual conditions or the suitability of products for specific applications.

The above warranty and repair or replacement obligation does not apply to or include:

- Any product that is not sold by Versa-Matic as new
- Any accessory or other product that does not bear a Versa-Matic brand (In the case of such products, any warranty is limited to a pass through to the original end-use purchaser of any warranty received from the manufacturer to the extent such pass through is permitted by the manufacturer)
- Any product that fails other than during normal use and service or that fails outside the warranty period for such product
- Normal wear and tear
- Any product that Versa-Matic determines (a) was tampered with, disassembled, repaired, modified or altered without the prior written authorization of Versa-Matic (b) damaged during or after shipment (c) used to pump material that the product was not designed to pump or otherwise used for a purpose or under conditions that differ from those for which it was designed (d) not properly maintained or operated or otherwise misused or (e) subjected to abnormal use or service.
- Any party other than the original end-use purchaser
- Field repair, removal, reinstallation, labor, freight or other similar items

To be eligible for warranty repair or replacement, the original end-use purchaser must notify Versa-Matic of the product failure in writing within the warranty period for such product and, if requested by Versa-Matic, the product must be promptly returned for inspection, freight prepaid, to either Versa-Matic's factory at 800 North Main Street; Mansfield, OH 44901 or to a Versa-Matic authorized distributor. The original end-user purchaser must also promptly provide Versa-Matic or its authorized distributor with all such information as either of them may request concerning the maintenance, operation, use and failure of any product that is claimed to have failed due to a defect in material or workmanship. Return of a product to Versa-Matic's factory requires a Return Goods authorization (RGA) from Versa-Matic, and the RGA No. must be included with the returned product. The original end-user purchaser shall bear all risk of loss or damage during shipment.

**THIS PRODUCT WARRANTY IS VERSA-MATIC'S SOLE AND EXCLUSIVE WARRANTY AND IS IN LIEU OF ALL OTHER WARRANTIES, EXPRESS OR IMPLIED, INCLUDING, BUT NOT LIMITED TO, ALL WARRANTIES OF MERCHANTABILITY AND FITNESS FOR A PARTICULAR PURPOSE, ALL OF WHICH OTHER WARRANTIES ARE EXPRESSLY EXCLUDED.**

**THE RIGHTS AND REMEDIES UNDER THIS PRODUCT WARRANTY ARE THE SOLE AND EXCLUSIVE RIGHTS AND REMEDIES AGAINST VERSA-MATIC WITH RESPECT TO ALL PRODUCTS. EXCEPT FOR THE SPECIFIC LIABILITIES AND OBLIGATIONS PROVIDED UNDER THIS PRODUCT WARRANTY, VERSA-MATIC SHALL HAVE NO LIABILITY OR OBLIGATION WITH RESPECT TO ANY PRODUCT.**

**UNDER NO CIRCUMSTANCES SHALL VERSA-MATIC HAVE ANY LIABILITY FOR ANY CLAIM, LOSS, DAMAGE, INJURY, LIABILITY, OBLIGATION, COST OR EXPENSE THAT DIRECTLY OR INDIRECTLY RELATES TO OR ARISES OUT OF THE USE OR FAILURE OF ANY PRODUCT OR ANY LIABILITY FOR INDIRECT, SPECIAL, PUNITIVE OR CONSEQUENTIAL DAMAGES, INCLUDING, BUT NOT LIMITED TO, LOSS OF SALES, LOSS OF PROFITS, LOSS OF MATERIAL BEING PUMPED, DOWN TIME, LOSS OF PRODUCTION, LOSS OF CONTRACTS, OR DAMAGE TO REPUTATION OR GOOD WILL, WHETHER OR NOT VERSA-MATIC WAS AWARE OF OR ADVISED OF THE POSSIBILITY OF SUCH DAMAGES.**

**IN ANY EVENT, VERSA-MATIC'S LIABILITY IN CONNECTION WITH ANY INDIVIDUAL PRODUCT SHALL BE LIMITED TO THE ORIGINAL PRICE PAID TO VERSA-MATIC FOR SUCH PRODUCT.**

***No Versa-Matic authorized distributor or other person is authorized to modify this Product Warranty or impose any liability or obligation on Versa-Matic other than as expressly provided herein.***

# PUMPER PARTS®

## The Only Difference is the Price.

Pumper Parts is your single source for Air-Operated Double Diaphragm (AODD) pump parts. The company was formed to meet the demands for faster delivery of replacement parts at competitive prices. Pumper Parts is a global supplier of quality replacement parts that fit **ARO®**, **Wilden®**, and **Yamada®** air-operated double diaphragm pumps.

Pumper Parts serves customers all over the world in a variety of markets, including chemical, paints & coatings, food processing, pharmaceutical, construction, mining, utilities, pulp & paper, metal finishing, and general industrial. A worldwide network of fully-stocked distributors and an extensive staff of qualified professionals are committed to supporting these customers. Pumper Parts is housed in a state-of-the-art facility to ensure that proper stock levels are maintained.

*Pumper Parts and its products are not affiliated with any of the original equipment manufacturers referenced herein. All original equipment manufacturers' names, colors, pictures, descriptions and part numbers are used for identification purposes only.*

*Pumper Parts® is a registered trade name of IDEX Corporation. All other trademarks, registered trademarks and product names are the property of their respective owners.*

### The Pumper Parts Promise

All Pumper Parts products are:

- Engineered to perform as well as or better than OEM parts — guaranteed
- Manufactured to meet or exceed the highest quality standards in the industry
- Honored with the same repair parts warranty as the OEM
- Priced competitively — providing savings and value



### Pumper Parts Tools

The Pumper Parts website helps you find

the parts you need fast and efficiently by allowing searches by product number or description. Additionally, a Chemical Compatibility database is provided so that you can quickly find what materials are most compatible with a variety of liquids.



### PUMPER PARTS®

IDEX AODD, Inc.  
A Unit of IDEX Corporation  
800 North Main Street, P.O. Box 1568  
Mansfield, OH 44901-1568 • USA

Phone: (419) 526-7296  
Fax: (419) 526-7289  
www.pumperparts.com  
info@pumperparts.com

# DECLARATION OF CONFORMITY

DECLARATION DE CONFORMITE • DECLARACION DE CONFORMIDAD • ERKLÄRUNG BEZÜGLICH EINHALTUNG DER VORSCHRIFTEN  
DICHIARAZIONE DI CONFORMITÀ • CONFORMITEITSVERKLARING • DEKLARATION OM ÖVERENSSTÄMMELSE  
EF-OVERENSSTÄMMELSESERKLÆRING • VAATIMUSTENMUKAISUUSVAKUUTUS • SAMSVARERKLÄRING • DECLARAÇÃO DE CONFORMIDADE

## MANUFACTURED BY:

FABRIQUE PAR:  
FABRICADA POR:  
HERGESTELLT VON:  
FABBRICATO DA:  
VERVAARDIGD DOOR:  
TILLVERKAD AV:  
FABRIKANT:  
VALMISTAJA:  
PRODUSENT:  
FABRICANTE:

**VERSA-MATIC®**  
IDEX AODD, Inc.  
A Unit of IDEX Corporation  
800 North Main Street, P.O. Box 1568  
Mansfield, OH 44901-1568 • USA  
Phone: (419) 526-7296  
Fax: (419) 526-7289

**VERSA-MATIC®**

## PUMP MODEL SERIES: E1 SERIES, E2 SERIES, E3 SERIES, E4 SERIES, E5 SERIES, E7 SERIES, E8 SERIES AND U2 SERIES:

### This product complies with the following European Community Directives:

**98 / 37 / EC**

Ce produit est conforme aux directives de la Communauté européenne suivantes:  
Este producto cumple con las siguientes Directrices de la Comunidad Europea:  
Dieses produkt erfüllt die folgenden Vorschriften der Europäischen Gemeinschaft:  
Questo prodotto è conforme alle seguenti direttive CEE:  
Dir produkt voldoet aan de volgende EG-richtlijnen:  
Denna produkt överensstämmer med följande EU direktiv:  
Versa-Matic, Inc., erklærer herved som fabrikant, at ovennævnte produkt er i overensstemmelse med bestemmelserne i Direktive:  
Tämä tuote täyttää seuraavien EC Direktiivien vaatimukset:  
Dette produkt oppfyller kravene til følgende EC Direktiver:  
Este produto está de acordo com as seguintes Directivas comunitárias:

### This product has used the following harmonized standards to verify conformance:

**EN 809**

Ce matériel est fabriqué selon les normes harmonisées suivantes, afin d' en garantir la conformité:  
Este producto cumple con las siguientes directrices de la comunidad europea:  
Dieses produkt ist nach folgenden harmonisierten standards gefertigt worden, die übereinstimmung wird bestätigt:  
Questo prodotto ha utilizzato i seguenti standards per verificare la conformità:  
De volgende geharmoniseerde normen werden gehanteerd om de conformiteit van dit produkt te garanderen:  
För denna produkt har följande harmoniserande standarder använts för att bekräfta överensstämmelse:  
Harmoniserede standarder, der er benyttet:  
Tässä tuotteessa on sovellettu seuraavia yhdenmukaistettuja standardeja:  
Dette produkt er produsert i overensstemmelse med følgende harmoniserte standarder:  
Este produto utilizou os seguintes padrões harmonizados para verificar conformidade:

## AUTHORIZED/APPROVED BY:

Approuve par:  
Aprobado por:  
Genehmigt von:  
approvato da:  
Goedgekeurd door:  
Underskrift:  
Valtuutettuna:  
Bemyndiget av:  
Autorizado Por:

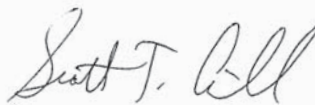

Scott Aiello  
Vice President of  
Commercial Operations



Erik Dillen,  
Engineering Manager

**DATE: March 11, 2008**

FECHA:  
DATUM:  
DATA:  
DATO:  
PÄIVÄYS:



