

**SERVICE & OPERATING MANUAL**  
Original Instructions



Quality System  
ISO9001 Certified

Environmental  
Management System  
ISO14001 Certified



**Versa-Surge  
Surge Suppressor  
for Air-Driven  
Diaphragm Pumps**

**Metallic Construction**



See page 15  
for ATEX ratings



**Table of Contents**

Surge Suppressor General Information.....	1
Product Model Nomenclature.....	2, 3
Materials and Operating Temperatures .....	3
Dimensions.....	4, 5
Installation Guide .....	6
Surge Suppressor Options .....	7
Grounding the Surge Suppressor.....	8
Service & Operating Instructions .....	10
Safety Information .....	10
Materials Codes.....	11
Repair Parts List.....	12
Parts Drawing .....	13
CE Declaration of Conformity - Machinery .....	14
CE Declaration of Conformity - ATEX & Explanation of Certification.....	15





Quality System  
ISO9001 Certified

Environmental  
Management System  
ISO14001 Certified



# Surge Suppressor

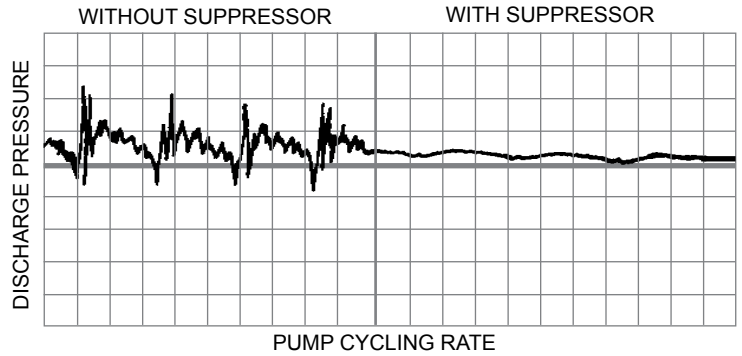

- Nearly surge-free flow.
- Steadier pressures.
- Less shock to pipes.

Air-operated diaphragm pumps offer a wide range of benefits not available in any other type of pump. However, in some applications, pulsations in the discharge flow may be undesirable. Pulsation can be virtually eliminated by installing a Versa-Matic® Surge Suppressor.

**At initial and subsequent start-ups . . .** air cushion is quickly established by liquid pressure pushing diaphragm upward, permitting entrance of air into air chamber, until the balancing air cushion causes the diaphragm to center at its mid-stroke normal operating position.

**During normal continuous operation thereafter . . .** the diaphragm always flexes at its mid-range position to absorb discharge pulsations against the adjoining air cushion already established.

**In event of change in pumped liquid pressure . . .** the air cushion pressure is automatically increased or decreased as required to compensate for the change . . . always maintaining constant volume of air cushion, and the diaphragm always operating at its mid-position.

**When liquid flow stops and liquid pressure is released . . .** the air in air chamber is also exhausted to atmosphere.

## Surge Suppressor

- Automatically maintains a constant volume of air cushion for most effective surge suppression, regardless of pump pressure.
- Automatically self-charging and self-venting to maintain most efficient air cushion pressure . . . no more precharge pressure calculations or guesswork, no manual pressurizing, no periodic pressure checking.
- Air cushion separated from product by flexible diaphragm . . . prevents product aeration.
- External visual indication provides constant evidence of performance.
- Simple to install. Attention-free.



**Models VTA1 and VTA25**  
1-inch Surge Suppressor for use with 1-inch pumps  
*Air Supply connection is 1/4" NPT external pipe thread.*  
Maximum Operating Pressure – 125 psi.



**Models VTA1½ and VTA40**  
1½-inch Surge Suppressor for use with 1½-inch pumps  
*Air Supply connection is 1/4" NPT external pipe thread.*  
Maximum Operating Pressure – 125 psi.



**Models VTA2 and VTA50**  
**Design Level 2**  
2-inch Surge Suppressor for use with 1½, 2-inch pumps  
*Air Supply connection is 1/4" NPT external pipe thread.*  
Maximum Operating Pressure – 125 psi.

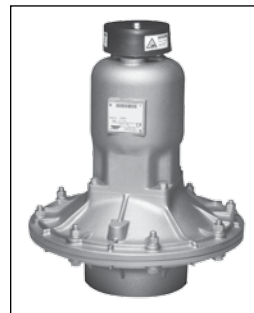

**Models VTA3 and VTA80**  
**Design Level 2**  
3-inch Surge Suppressor for use with 3-inch pumps  
*Air Supply connection is 1/4" NPT external pipe thread.*  
Maximum Operating Pressure – 125 psi.

# Materials of Construction:

Type Code	Diaphragm	Design Level	Wetted Parts	Porting (Internal Tapered Threads)
-----------	-----------	--------------	--------------	------------------------------------

## Surge Suppressor Model VTA1

B-1-A	B	1	A	1" NPT
H-1-A	H	1	A	1" NPT
NG-1-A	NG	1	A	1" NPT
N-1-A	N	1	A	1" NPT
S-1-A	S	1	A	1" NPT
V-1-A	V	1	A	1" NPT
B-1-SS	B	1	SS	1" NPT
F-1-SS	F	1	SS	1" NPT
H-1-SS	H	1	SS	1" NPT
NG-1-SS	NG	1	SS	1" NPT
N-1-SS	N	1	SS	1" NPT
S-1-SS	S	1	SS	1" NPT
V-1-SS	V	1	SS	1" NPT

## Surge Suppressor Model VTA1½

B-1-A	B	1	A	1½" NPT
NG-1-A	NG	1	A	1½" NPT
N-1-A	N	1	A	1½" NPT
V-1-A	V	1	A	1½" NPT
B-1-A	B	1	A	1½" NPT
F-1-A	F	1	A	1½" NPT
NG-1-SS	NG	1	SS	1½" NPT
N-1-SS	N	1	SS	1½" NPT
V-1-SS	V	1	SS	1½" NPT

## Surge Suppressor Model VTA2 Design level 2

B-2-A	B	2	A	2" NPT
I-2-A	I	2	A	2" NPT
NG-2-A	NG	2	A	2" NPT
N-2-A	N	2	A	2" NPT
S-2-A	S	2	A	2" NPT
V-2-A	V	2	A	2" NPT
B-2-CI	B	2	CI	2" NPT
I-2-CI	I	2	CI	2" NPT
NG-2-CI	NG	2	CI	2" NPT
N-2-CI	N	2	CI	2" NPT
S-2-CI	S	2	CI	2" NPT
V-2-CI	V	2	CI	2" NPT
B-2-SS	B	2	SS	2" NPT
F-2-SS	F	2	SS	2" NPT

Type Code	Diaphragm		Design Level	Wetted Parts	Porting (Internal Tapered Threads)	Porting Flange Style	Shipping Weight lbs./kg
-----------	-----------	--	--------------	--------------	------------------------------------	----------------------	-------------------------

## Surge Suppressor Model VTA25

B-1-A	B		1	A	1" BSPT		14 / 6.35
H-1-A	H		1	A	1" BSPT		14 / 6.35
NG-1-A	NG		1	A	1" BSPT		14 / 6.35
N-1-A	N		1	A	1" BSPT		14 / 6.35
S-1-A	S		1	A	1" BSPT		14 / 6.35
V-1-A	V		1	A	1" BSPT		14 / 6.35
B-1-SS	B		1	SS	1" BSPT		18 / 8.16
F-1-SS	F		1	SS	1" BSPT		18 / 8.16
H-1-SS	H		1	SS	1" BSPT		18 / 8.16
NG-1-SS	NG		1	SS	1" BSPT		18 / 8.16
N-1-SS	N		1	SS	1" BSPT		18 / 8.16
S-1-SS	S		1	SS	1" BSPT		18 / 8.16
V-1-SS	V		1	SS	1" BSPT		18 / 8.16

## Surge Suppressor Model VTA40

B-1-A	B		1	A	1½" BSPT		28 / 12.7
NG-1-A	NG		1	A	1½" BSPT		28 / 12.7
N-1-A	N		1	A	1½" BSPT		28 / 12.7
V-1-A	V		1	A	1½" BSPT		28 / 12.7
B-1-SS	B		1	SS	1½" BSPT		35 / 15.9
F-1-SS	F		1	SS	1½" BSPT		35 / 15.9
NG-1-SS	NG		1	SS	1½" BSPT		35 / 15.9
N-1-SS	N		1	SS	1½" BSPT		35 / 15.9
V-1-SS	V		1	SS	1½" BSPT		35 / 15.9

## Surge Suppressor Model VTA50 Design level 2

B-2-A	B		2	A	2" BSPT		28 / 12.7
I-2-A	I		2	A	2" BSPT		28 / 12.7
NG-2-A	NG		2	A	2" BSPT		28 / 12.7
N-2-A	N		2	A	2" BSPT		28 / 12.7
S-2-A	S		2	A	2" BSPT		28 / 12.7
V-2-A	V		2	A	2" BSPT		28 / 12.7
B-2-CI	B		2	CI	2" BSPT		35 / 15.9
I-2-CI	I		2	CI	2" BSPT		35 / 15.9
NG-2-CI	NG		2	CI	2" BSPT		35 / 15.9
N-2-CI	N		2	CI	2" BSPT		35 / 15.9
S-2-CI	S		2	CI	2" BSPT		35 / 15.9
V-2-CI	V		2	CI	2" BSPT		35 / 15.9
B-2-SS	B		2	SS	2" BSPT		35 / 15.9
F-2-SS	F		2	SS	2" BSPT		35 / 15.9

# Materials of Construction continued:

## Surge Suppressor Model VTA2 Design level 2, continued

Type Code	Diaphragm	Design Level	Wetted Parts	Porting (Internal Tapered Threads)	Porting Flange Style
NG-2-SS	NG	2	SS	2" NPT	
N-2-SS	N	2	SS	2" NPT	
V-2-SS	V	2	SS	2" NPT	
I-2-HC	I	2	HC	2" NPT	
NG-2-HC	NG	2	HC	2" NPT	
N-2-HC	N	2	HC	2" NPT	
V-2-HC	V	2	HC	2" NPT	

## Surge Suppressor Model VTA50 Design level 2, continued

Type Code	Diaphragm	Design Level	Wetted Parts	Porting (Internal Tapered Threads)	Porting Flange Style	Shipping Weight lbs./kg
NG-2-SS	NG	2	SS	2" BSPT		35 / 15.9
N-2-SS	N	2	SS	2" BSPT		35 / 15.9
V-2-SS	V	2	SS	2" BSPT		35 / 15.9
I-2-HC	I	2	HC	2" BSPT		35 / 15.9
NG-2-HC	NG	2	SS	1½" BSPT		35 / 15.9
N-2-HC	N	2	HC	1½" BSPT		35 / 15.9
V-2-HC	V	2	HC	1½" BSPT		35 / 15.9

## Surge Suppressor Model VTA3 Design level 2

B-2-A	B	2	A	3" NPT	3" ANSI Style
I-2-A	I	2	A	3" NPT	3" ANSI Style
NG-2-A	NG	2	A	3" NPT	3" ANSI Style
N-2-A	N	2	A	3" NPT	3" ANSI Style
V-2-A	V	2	A	3" NPT	3" ANSI Style
B-2-CI	B	2	CI	3" NPT	3" ANSI Style
I-2-CI	I	2	CI	3" NPT	3" ANSI Style
NG-2-CI	NG	2	CI	3" NPT	3" ANSI Style
N-2-CI	N	2	CI	3" NPT	3" ANSI Style
V-2-CI	V	2	CI	3" NPT	3" ANSI Style
B-2-SS	B	2	SS	3" NPT	3" ANSI Style
NG-2-SS	NG	2	SS	3" NPT	3" ANSI Style
N-2-SS	N	2	SS	3" NPT	3" ANSI Style
V-2-SS	V	2	SS	3" NPT	3" ANSI Style

## Surge Suppressor Model VTA80 Design level 2

B-2-A	B	2	A	3" BSPT	PN10 80 mm DIN	89 / 40.4
I-2-A	I	2	A	3" BSPT	PN10 80mm DIN	89 / 40.4
NG-2-A	NG	2	A	3" BSPT	PN10 80mm DIN	89 / 40.4
N-2-A	N	2	A	3" BSPT	PN10 80mm DIN	89 / 40.4
V-2-A	V	2	A	3" BSPT	PN10 80mm DIN	89 / 40.4
B-2-CI	B	2	CI	3" BSPT	PN10 80mm DIN	109 / 49.4
I-2-CI	I	2	CI	3" BSPT	PN10 80mm DIN	109 / 49.4
NG-2-CI	NG	2	CI	3" BSPT	PN10 80mm DIN	109 / 49.4
N-2-CI	N	2	CI	3" BSPT	PN10 80mm DIN	109 / 49.4
V-2-CI	V	2	CI	3" BSPT	PN10 80mm DIN	109 / 49.4
B-2-SS	B	2	SS	3" BSPT	PN10 80mm DIN	105 / 47.6
NG-2-SS	NG	2	SS	3" BSPT	PN10 80mm DIN	105 / 47.6
N-2-SS	N	2	SS	3" BSPT	PN10 80mm DIN	105 / 47.6
V-2-SS	V	2	SS	3" BSPT	PN10 80mm DIN	105 / 47.6

### Meaning of Abbreviations:

A	=	Aluminum	H	=	Hytrel®	S	=	Santoprene®
B	=	Nitrile	I	=	EPDM	V	=	FKM (Fluorocarbon)
CI	=	Cast Iron	N	=	Neoprene	SS	=	Stainless Steel
F	=	FDA White Nitrile	NG	=	Neoprene Backup/PTFE Overlay	HC	=	Alloy C

Kit available to convert to top porting

\* Most other types available in dual ported design. See price book or consult factory for details.

Hytrel® are registered trademarks of E.I. du Pont. Santoprene® is a registered trademark of Exxon Mobil Corp. Versa-Matic is a registered trademark of Warren Rupp, Inc.

MATERIALS	Operating Temperatures	
	Maximum	Minimum
<b>NITRILE:</b> General purpose, oil-resistant. Shows good solvent, oil, water and hydraulic fluid resistance. Should not be used with highly polar solvents like acetone and MEK, ozone, chlorinated hydrocarbons and nitro hydrocarbons.	190°F 88°C	-10°F -23°C
<b>NEOPRENE:</b> All purpose. Resistant to vegetable oils. Generally not affected by moderate chemicals, fats, greases and many oils and solvents. Generally attacked by strong oxidizing acids, ketones, esters, nitro hydrocarbons and chlorinated aromatic hydrocarbons.	200°F 93°C	-10°F -23°C
<b>HYTREL®:</b> Good on acids, bases, amines, and glycols at room temperature.	220°F 104°C	-20°F -29°C
<b>VIRGIN PTFE:</b> Chemically inert, virtually impervious. Very few chemicals are known to chemically react with Teflon®, molten alkali metals, turbulent liquid or gases, fluorine and a few fluoro-chemicals such as chlorine trifluoride or oxygen difluoride which readily liberate free fluorine at elevated temperatures.	220°F 104°C	-35°F -37°C
<b>FKM:</b> Shows good resistance to a wide range of oils and solvents; especially all aliphatic, aromatic and halogenated hydrocarbons, acids, animal and vegetable oils. Hot water or hot aqueous solutions (over 70° F) will attack FKM.	350°F 177°C	-40°F -40°C
<b>EPDM:</b> Shows very good water and chemical resistance. Has poor resistance to oil and solvents, but is fair in ketones and alcohols.	280°F 138°C	-40°F -40°C
<b>SANTOPRENE®:</b> Injection molded thermoplastic elastomer with no fabric layer. Long mechanical flex life. Excellent abrasion resistance.	275°F 135°C	-40°F -40°C
<b>STAINLESS STEEL:</b> CF-8M equal to or exceeding ASTM specification A743 for corrosion resistant iron chromium, iron chromium nickel, and nickel based alloy castings for general applications. Commonly referred to as 316 Stainless Steel in the pump industry.		
<b>ALLOY C:</b> CW-12MW equal to or exceeding ASTM A494 specification for nickel and nickel alloy castings.		

For specific applications, always consult the Versa-Matic® "Chemical Resistance Chart".



II 2 G c T5  
II 3/2 G c T5  
II 2 D c T100°C

See page 15 for ATEX Explanation of Type Examination Certificate.

## Model VTA1

Air Inlet  
 1/4" NPT (external) fitting  
 FLUID Port - 1" NPT

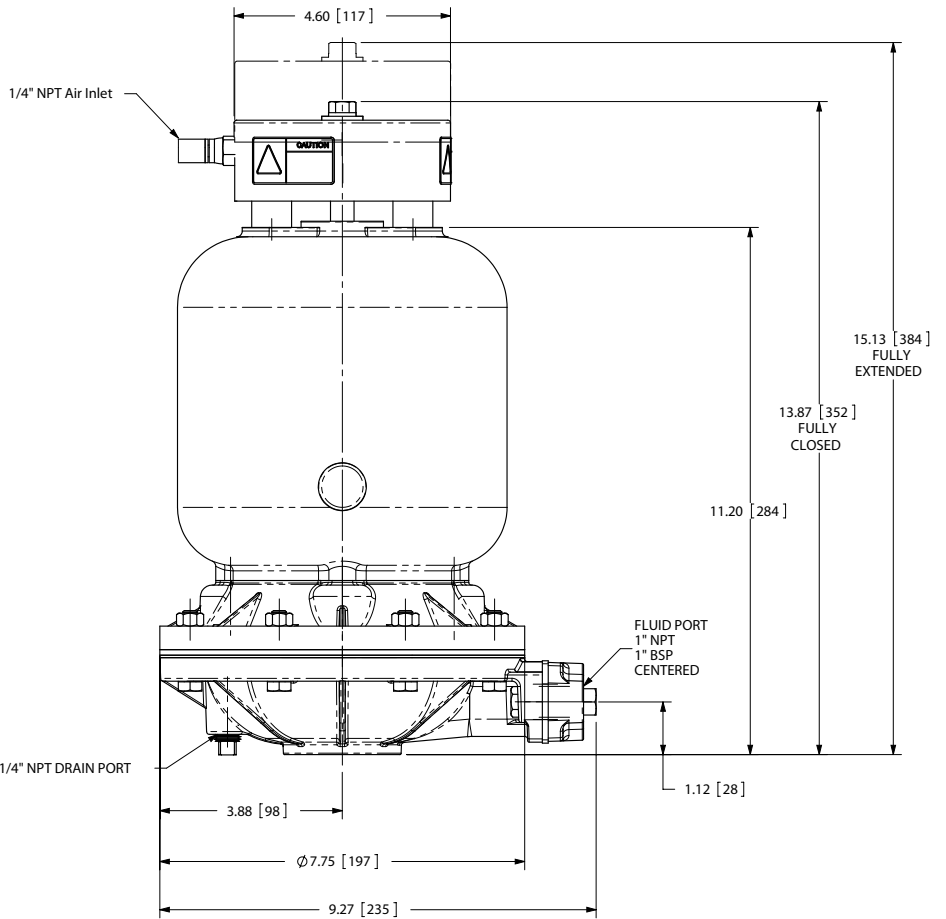

## Model VTA25

Air Inlet  
 1/4" NPT (external) fitting  
 FLUID Port - 1" BSP tapered thread

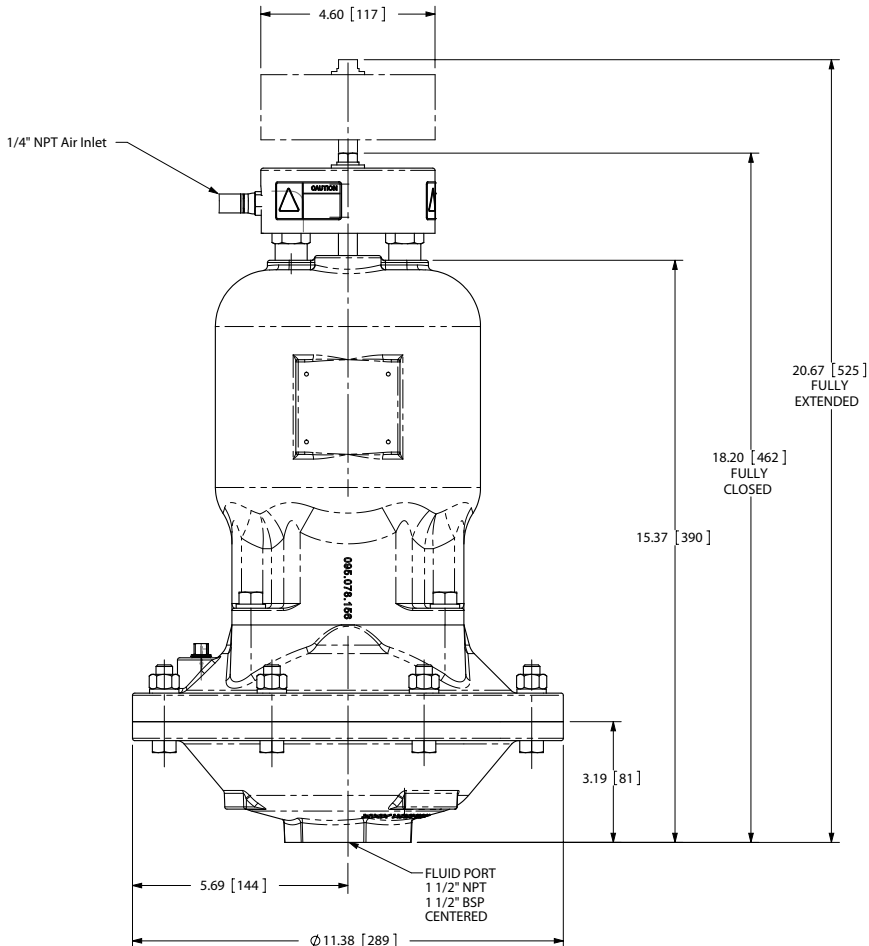

## Model VTA1 1/2

Air Inlet  
 1/4" NPT (external) fitting  
 FLUID Port - 1 1/2" NPT

## Model VTA40

Air Inlet  
 1/4" NPT (external) fitting  
 FLUID Port - 1 1/2" BSP tapered thread

All Dimensions ± .13" (3mm)

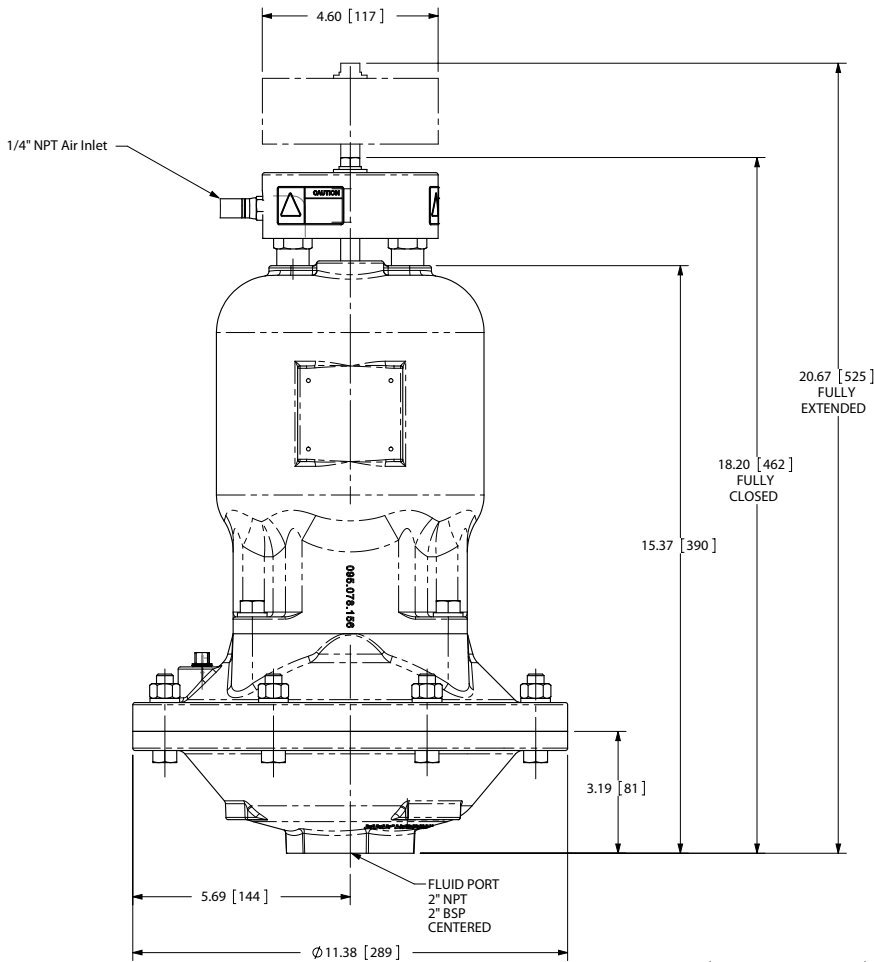

## Model VTA2

### Design Level 2

Air Inlet

1/4" NPT (external) fitting

2" NPT Fluid Port

## Model VTA50

### Design Level 2

Air Inlet

1/4" NPT (external) fitting

2" BSP(Tapered) Fluid Port

Port

## Model VTA3

### Design Level 2

Air Inlet

1/4" NPT (external) fitting

FLUID Port

## Model VTA80

### Design Level 2

Air Inlet

1/4" NPT (external) fitting

FLUID Port

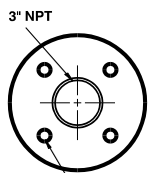

3" 150# FFANSI-style flange  
5/8-11 unc. 2B  
4 holes equally spaced on  
a 6" diameter bolt circle

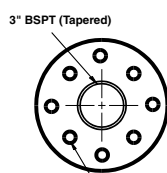

PN10 80mm DIN Flange  
M16x2 Ø holes on a  
160mm diameter Bolt Circle

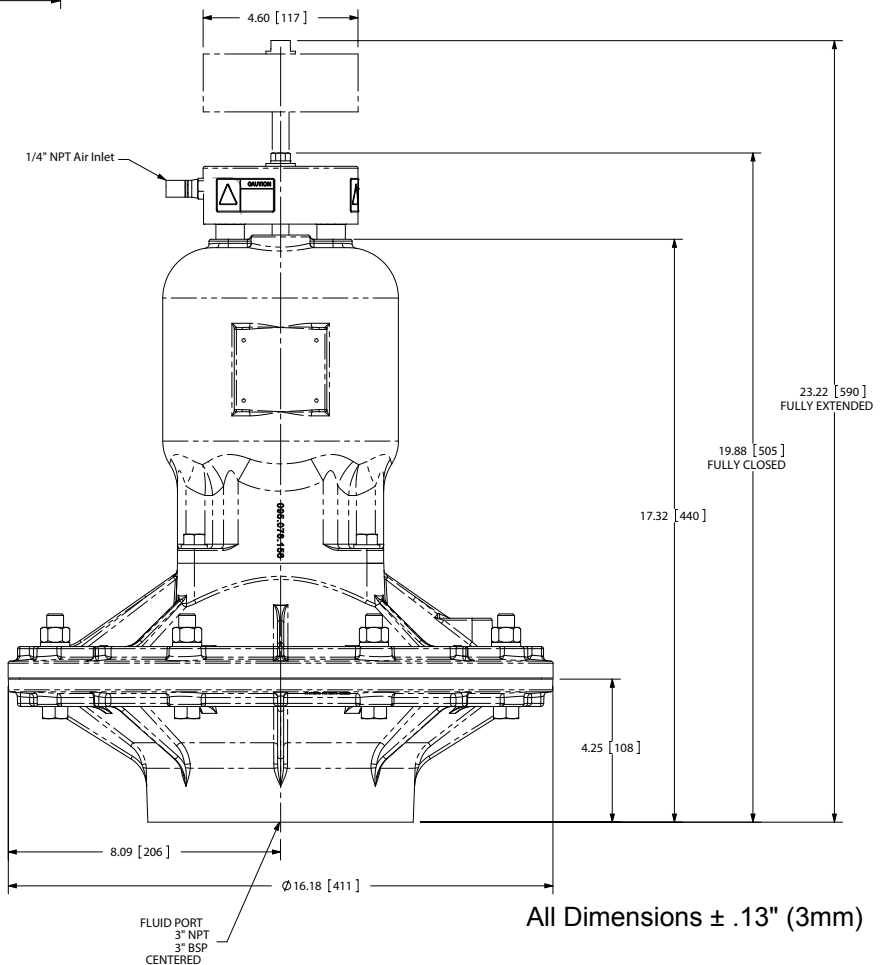

All Dimensions ± .13" (3mm)

# INSTALLATION GUIDE

## Top Discharge Ball or Flap Valve Unit



Available from  
Versa-Matic

- ① Surge Suppressor
- ② Filter/Regulator
- ③ Lubricator
- ④ Air Dryer

	<p><b>CAUTION</b></p> <p>The air exhaust should be piped to an area for safe disposition of the product being pumped, in the event of a diaphragm failure.</p>
--	--

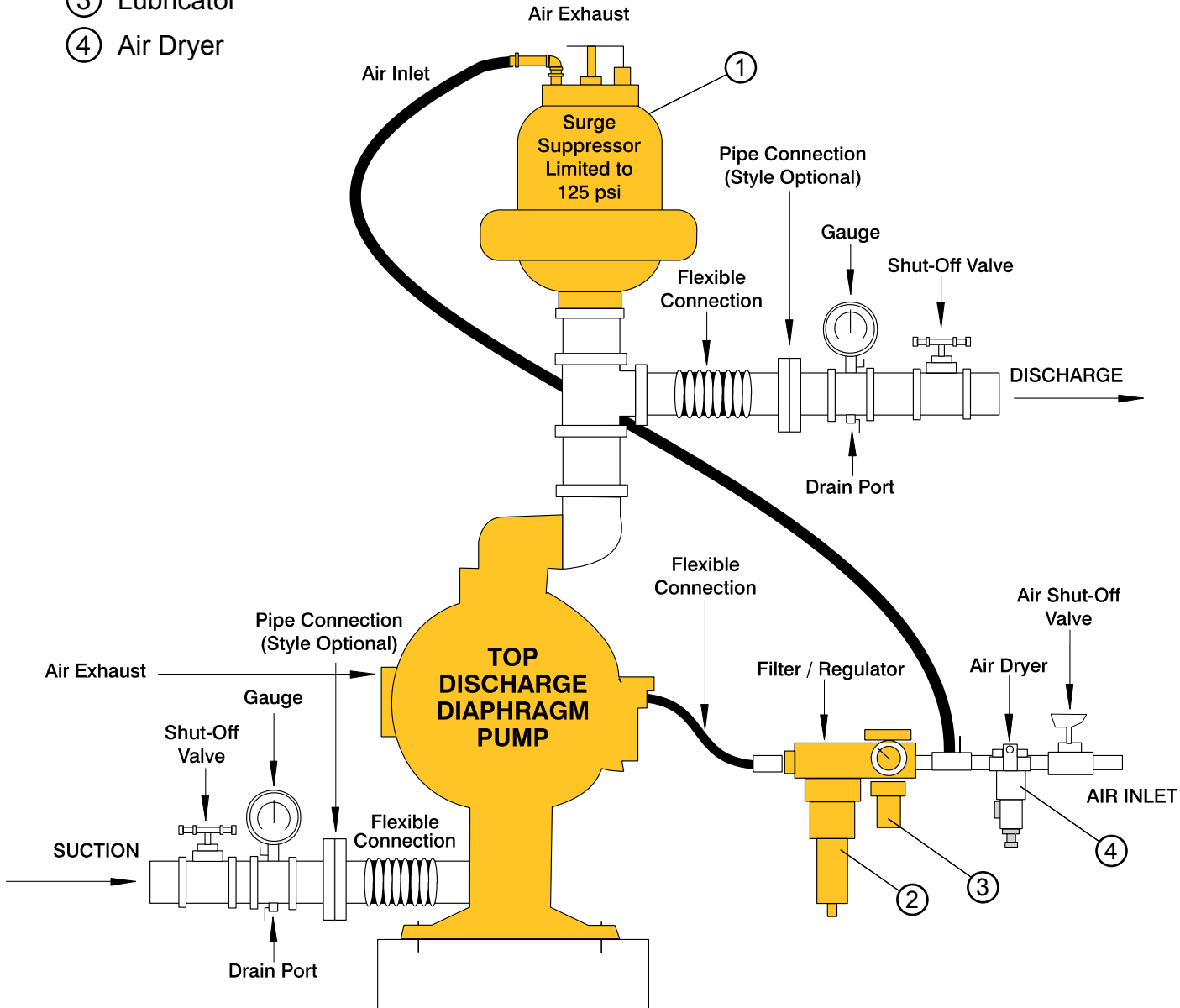



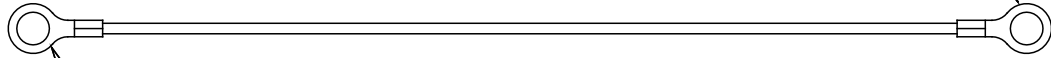

# Grounding The Surge Suppressor

One eyelet end is fastened to the surge suppressor hardware.

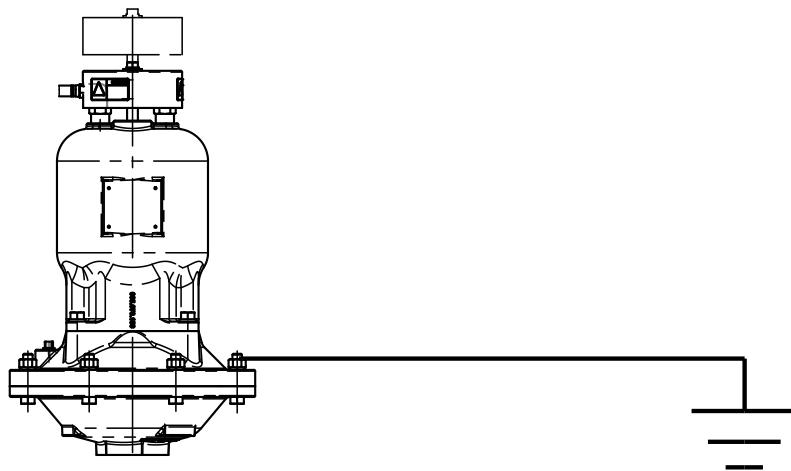

The other end is installed to a true earth ground.



	<p><b>! WARNING</b></p> <p><i>Take action to prevent static sparking. Fire or explosion can result, especially when handling flammable liquids. The pump, piping, valves, containers or other miscellaneous equipment must be grounded.</i></p>
---	---

This optional 8 foot long (244 centimeters) Ground Strap (920-025-000) is available for easy ground connection.

To reduce the risk of static electrical sparking, this surge suppressor must be grounded. Check the local electrical code for detailed grounding instruction and the type of equipment required.





# Surge Suppressor

## Model VTA80

### Metallic Construction

## SERVICE AND OPERATING INSTRUCTIONS

This Versa-Matic® Surge Suppressor is a completely automatic diaphragm fitted surge suppressor to reduce the flow and pressure pulsations in a pumping system characteristic of reciprocating type pumps.

**Principle of Operation:** The Surge Suppressor uses a flexible diaphragm to separate a liquid chamber from compressed air chambers. A rod connected to the center of one diaphragm activates the air inlet and exhaust valves, which automatically admit or exhaust air in the air chambers. This maintains the diaphragms in mid-range of stroke for maximum surge suppression.

**Installation:** Locate the Surge Suppressor in discharge piping as close as possible to the pump. The unit will operate in any position. Connect air inlet connection to full plant air supply line before the air regulator to pump. Not to exceed 125PSI.

**Service Instructions:** When service is required, it is important to MAKE CERTAIN THAT INLET AIR PRESSURE IS DISCONNECTED. The diaphragms are serviced by simply removing the hex nuts or v-band, and removing the center spool casting. When Virgin PTFE diaphragms are used in conjunction with the elastomeric diaphragms they are placed over the “wetted” sides of each elastomeric diaphragm. Inlet and exhaust air valves are located externally for easy access and service.

**Warranty:** This unit is guaranteed for a period of five years against defective material and workmanship.

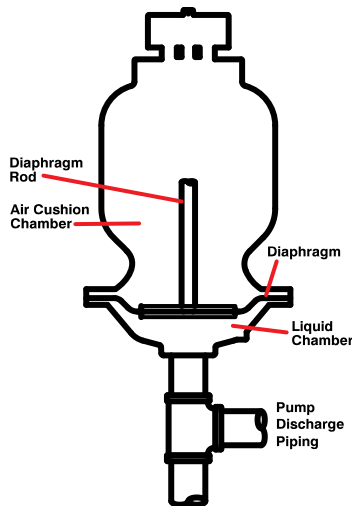

### ! IMPORTANT

*Read these safety warnings and instructions in this manual completely, before installation and start-up of the pulsation dampener. It is the responsibility of the purchaser to retain this manual for reference. Failure to comply with the recommendations stated in this manual will damage the pulsation dampener, and void factory warranty.*



### ! CAUTION

*Before surge suppressor operation, inspect all gasketed fasteners for looseness caused by gasket creep. Re-torque loose fasteners to prevent leakage. Follow recommended torques stated in this manual.*



### ! WARNING

*Before doing any maintenance on the pulsation dampener, be certain all pressure is completely vented from the pump, suction, discharge, piping, and all other openings and connections. Be certain the air supply is locked out or made non-operational, so that it cannot be started while work is being done on the pump. Be certain that approved eye protection and protective clothing are worn all times in the vicinity of the pump. Failure to follow these recommendations may result in serious injury or death.*



### ! WARNING

*Take action to prevent static sparking. Fire or explosion can result, especially when handling flammable liquids. The pump, piping, valves, containers or other miscellaneous equipment must be grounded. See page 8.*

### ! HAZARD WARNING !

*POSSIBLE EXPLOSION HAZARD can result if 1, 1, 1, -Trichloroethane, Methylene Chloride or other Halogenated Hydrocarbon solvents are used in pressurized fluid systems having Aluminum or Galvanized wetted parts. Death, serious bodily injury and/or property damage could result. Consult with the factory if you have questions concerning Halogenated Hydrocarbon solvents.*

# MATERIAL CODES

## THE LAST 3 DIGITS OF PART NUMBER

000	Assembly, sub-assembly; and some purchased items	337	Silver Plated Steel	555	Polyvinyl Chloride
010	Cast Iron	340	Nickel Plated	556	Black Vinyl
012	Powered Metal	342	Filled Nylon	558	Conductive HDPE
015	Ductile Iron	351	Food Grade Santoprene	570	Rulon II
020	Ferritic Malleable Iron	353	Geolast; Color: Black	580	Ryton
025	Music Wire	354	Injection Molded #203-40 Santoprene- Duro 40D +/-5; Color: RED	590	Valox
080	Carbon Steel, AISI B-1112			591	Nylatron G-S
100	Alloy 20	355	Thermal Plastic	592	Nylatron NSB
110	Alloy Type 316 Stainless Steel	356	Hytrell	600	PTFE (virgin material) Tetrafluorocarbon (TFE)
111	Alloy Type 316 Stainless Steel (Electro Polished)	357	Injection Molded Polyurethane	601	PTFE (Bronze and moly filled)
112	Alloy C	358	Urethane Rubber (Some Applications) (Compression Mold)	602	Filled PTFE
113	Alloy Type 316 Stainless Steel (Hand Polished)			603	Blue Gylon
114	303 Stainless Steel	359	Urethane Rubber	604	PTFE
115	302/304 Stainless Steel	360	Nitrile Rubber Color coded: RED	606	PTFE
117	440-C Stainless Steel (Martensitic)	361	Nitrile	607	Envelon
120	416 Stainless Steel (Wrought Martensitic)	363	FKM (Fluorocarbon). Color coded: YELLOW	608	Conductive PTFE
123	410 Stainless Steel (Wrought Martensitic)	364	E.P.D.M. Rubber. Color coded: BLUE	610	PTFE Encapsulated Silicon
148	Hardcoat Anodized Aluminum	365	Neoprene Rubber. Color coded: GREEN	611	PTFE Encapsulated FKM
149	2024-T4 Aluminum	366	Food Grade Nitrile	632	Neoprene/Hytrel
150	6061-T6 Aluminum	368	Food Grade EPDM	633	FKM/PTFE
151	6063-T6 Aluminum	370	Butyl Rubber	634	EPDM/PTFE
152	2024-T4 Aluminum (2023-T351)			635	Neoprene/PTFE
154	Almag 35 Aluminum	371	Philthane (Tuftane)	637	PTFE, FKM/PTFE
155	356-T6 Aluminum	374	Carboxylated Nitrile	638	PTFE, Hytrel/PTFE
156	356-T6 Aluminum	375	Fluorinated Nitrile	639	Nitrile/TFE
157	Die Cast Aluminum Alloy #380	378	High Density Polypropylene	643	Santoprene®/EPDM
158	Aluminum Alloy SR-319	379	Conductive Nitrile	644	Santoprene®/PTFE
159	Anodized Aluminum	405	Cellulose Fibre	656	Santoprene Diaphragm and Check Balls/EPDM Seats
162	Brass, Yellow, Screw Machine Stock	408	Cork and Neoprene	661	EPDM/Santoprene
165	Cast Bronze, 85-5-5-5	425	Compressed Fibre	666	FDA Nitrile Diaphragm, PTFE Overlay, Balls, and Seals
166	Bronze, SAE 660	426	Blue Gard	668	PTFE, FDA Santoprene/PTFE
170	Bronze, Bearing Type, Oil Impregnated	440	Vegetable Fibre		
175	Die Cast Zinc	465	Fibre		
180	Copper Alloy	500	Delrin 500		
305	Carbon Steel, Black Epoxy Coated	501	Delrin 570		
306	Carbon Steel, Black PTFE Coated	502	Conductive Acetal, ESD-800		
307	Aluminum, Black Epoxy Coated	503	Conductive Acetal, Glass-Filled		
308	Stainless Steel, Black PTFE Coated	505	Acrylic Resin Plastic		
309	Aluminum, Black PTFE Coated	506	Delrin 150		
310	PVDF Coated	520	Injection Molded PVDF Natural color		
313	Aluminum, White Epoxy Coated	540	Nylon		
330	Zinc Plated Steel	541	Nylon		
331	Chrome Plated Steel	542	Nylon		
332	Aluminum, Electroless Nickel Plated	544	Nylon Injection Molded		
333	Carbon Steel, Electroless Nickel Plated	550	Polyethylene		
335	Galvanized Steel	551	Glass Filled Polypropylene		
336	Zinc Plated Yellow Brass	552	Unfilled Polypropylene		
		553	Unfilled Polypropylene		

Delrin and Hytrel are registered tradenames of E.I. DuPont.

Gylon is a registered tradename of Garlock, Inc.

Nylatron is a registered tradename of Polymer Corp.

Santoprene is a registered tradename of Exxon Mobil Corp.

Rulon II is a registered tradename of Dixon Industries Corp.

Ryton is a registered tradename of Phillips Chemical Co.

Valox is a registered tradename of General Electric Co.

Versa-Matic is a registered tradename of Warren Rupp, Inc.



# REPAIR PARTS LIST and DRAWING Surge Suppressor Model VTA80



Design Level 2  
Metallic Construction

ITEM NO.	PART NUMBER	DESCRIPTION	QTY.
1	070.014.170	Bearing, Sleeve	1
2	095.078.156	Body	1
3	165.023.000	Cap	1
4	170.005.330	Capscrew, Hex Hd - 5/16-18 X 7/8	1
5	170.024.330	Capscrew, Hex Hd - 7/16-14 X 1	4
6	170.082.330	Capscrew, Hex Hd, 1/2-13UNC X 2.75	8
7	196.100.015	Chamber, Inner	1
8	196.146.156E	Chamber, Outer (3" BSP Tapered/PN10 80mm DIN)	1
	196.146.010E	Chamber, Outer (3" BSP Tapered/PN10 80mm DIN)	1
	196.146.110E	Chamber, Outer (3" BSP Tapered/PN10 80mm DIN)	1
<b>9</b>	<b>286.098.604</b>	<b>Diaphragm, Overlay</b>	<b>1</b>
<b>10</b>	<b>286.098.360</b>	<b>Diaphragm</b>	<b>1</b>
	<b>286.098.363</b>	<b>Diaphragm</b>	<b>1</b>
	<b>286.098.364</b>	<b>Diaphragm</b>	<b>1</b>
	<b>286.098.365</b>	<b>Diaphragm</b>	<b>1</b>
	<b>286.098.354</b>	<b>Diaphragm</b>	<b>1</b>
	<b>286.098.351</b>	<b>Diaphragm</b>	<b>1</b>
11	866.078.330	Tube Fitting	1
12	545.008.330	Nut, Hex - 1/2-13	9
13	560.022.360	O-Ring	1
14	612.043.330	Plate, Activator	1
15	612.044.330	Plate, Activator	1
16	612.192.157	Plate, Inner Diaphragm	1
17	612.194.157	Plate, Outer Diaphragm Assy. (Alum Units Only)	1
	612.194.010	Plate, Outer Diaphragm Assy. (Cast Iron Units Only)	1
	612.194.110	Plate, Outer Diaphragm Assy. (Stainless Units Only)	1
18	675.054.080	Ring, Retainer	1
19	685.066.120	Rod, Diaphragm	1
20	685.048.120	Rod, Activator	1
<b>21</b>	<b>720.012.360</b>	<b>U-cup, Shaft Seal</b>	<b>1</b>
23	893.021.000	Valve Assembly	1
23.1	095.020.162	Body, Valve	1
23.2	560.001.360	O-Ring	1
23.3	622.002.162	Poppet	1
23.4	670.007.162	Spring Retainer	1
23.5	780.013.115	Spring, Compression	1
24	893.023.000	Valve Assembly	1
24.1	095.019.162	Body, Valve	1
24.2	622.002.162	Poppet	1
24.3	780.013.115	Spring, Compression	1
24.4	560.001.360	O-Ring	1
24.5	866.010.162	Elbow, Male	1
25	900.003.330	Washer, Lock - 1/2	8
26	900.004.330	Washer, Lock - 5/16	1
27	900.006.330	Washer, Lock - 7/16	4
28	901.009.115	Washer, Flat - 5/16	1

# Model VTA80 Design Level 2

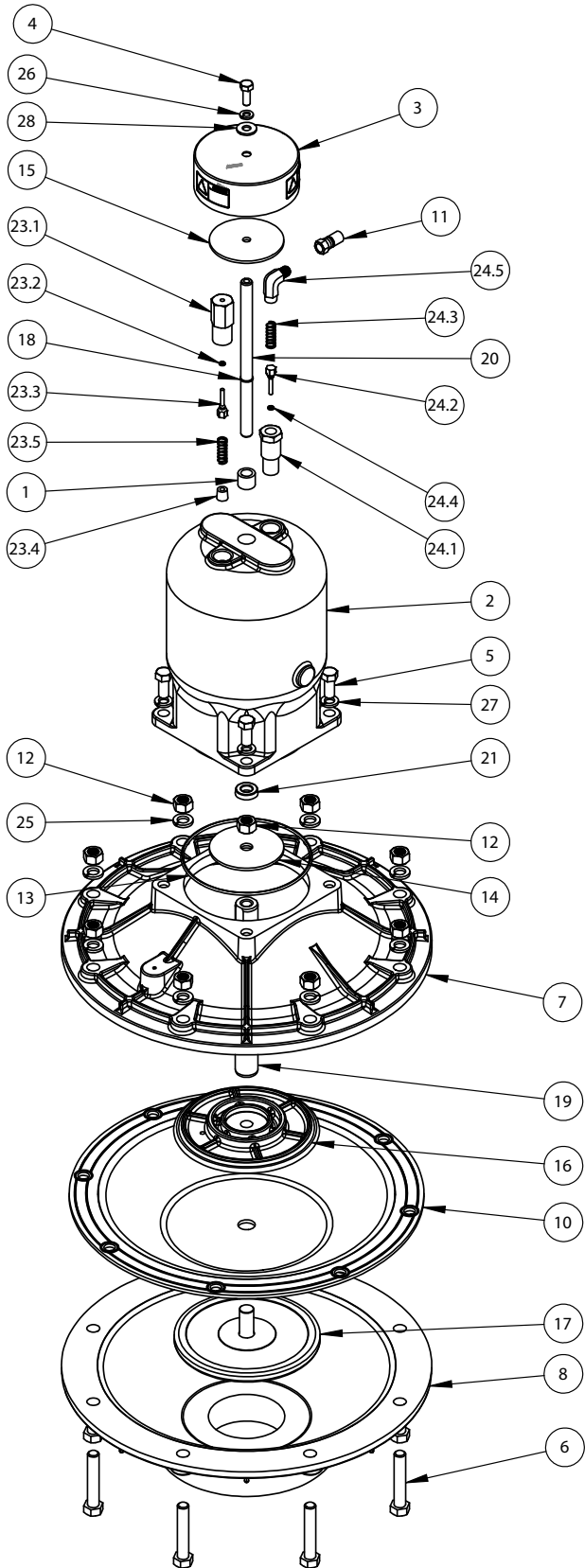

## PTFE Fitted Units

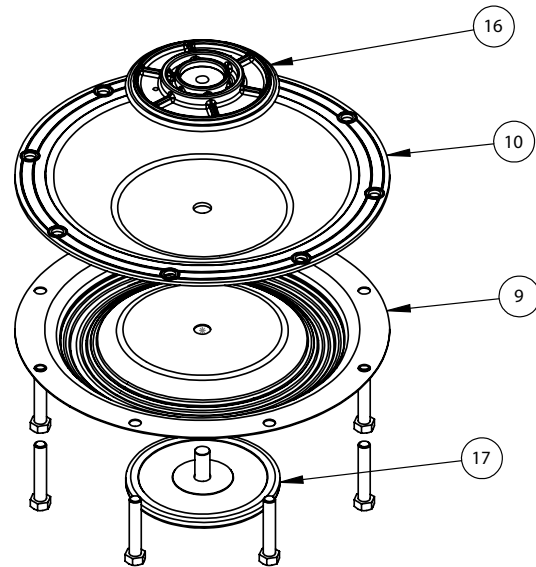

U.S. PATENT NO. 3741692

©2010 Warren Rupp, Inc. All rights reserved.

®Versa-Matic is a registered tradename of Warren Rupp, Inc.

Printed in U.S.A.

Declaration of Conformity

Declaration of Conformity



## Declaration of Conformity

**Manufacturer:**

**Versa-Matic®**, Warren Rupp, Inc., 800 N. Main Street, P.O. Box 1568,  
Mansfield, Ohio, 44901-1568 USA

Certifies that Air-Operated Double Diaphragm Pump Series:  
Non-Metallic E Series, VTA Series Metallic Surge Suppressors and  
VDA Non-Metallic Surge Dampeners comply with the European Community  
Directive 2006/42/EC on Machinery, according to Annex VIII. This product  
has used Harmonized Standard EN 809, Pumps and Pump Units  
for Liquids - Common Safety Requirements, to verify conformance.

David Roseberry  
Signature of authorized person

David Roseberry  
Printed name of authorized person

Revision Level: C

October 17, 2007  
Date of issue

Engineering Manager  
Title

May 27, 2010  
Date of revision





# Declaration of Conformity ATEX 95

In accordance with Directive 94/9/EC, Annex III  
Equipment intended for use in potentially explosive environments.

**MANUFACTURER:**

Versa-Matic®, Warren Rupp, Inc.  
A Unit of IDEX Corporation  
800 North Main Street  
P.O. Box 1568  
Mansfield, OH 44901-1568 USA

**APPLICABLE STANDARDS:**

94/9/EC  
EN13463-1: 2001, EN13463-5: 2003  
For potentially explosive environments

**MODELS:**

**Metal Surge Suppressors Series:**  
Versa-Surge Brand VTA Models

II 2 G T5  
II 3/2 G T5  
II 2 D T100°C  
**Type Examination Certificate**  
**KEMA 09ATEX0073 CE**



**Air-Operated Double Diaphragm  
Non-metallic Conductive Acetal  
Pump Model: E6**

II 1 G c T5  
II 3/1 G c T5  
II 1 D c T100°C  
**Type Examination Certificate**  
**KEMA 09ATEX0071 X**  
**CE 0344**



**Versa-Surge**

**DATE/APPROVAL/TITLE:**  
27 May 2010

David Roseberry, Engineering Manager